

General Quick Study Guide 2023-2027

2023-2027 General Class Pool

SUBLELEMENT G1

COMMISSION'S RULES

[5 Exam Questions – 5 Groups]

G1A – General class control operator frequency privileges; primary and secondary allocations

G1A01 On which HF and/or MF amateur bands are there portions where General class licensees cannot transmit?

80 meters, 40 meters, 20 meters, and 15 meters

G1A02 On which of the following bands is phone operation prohibited?

30 meters

G1A03 On which of the following bands is image transmission prohibited?

30 meters

G1A04 Which of the following amateur bands is restricted to communication only on specific channels, rather than frequency ranges?

60 meters

G1A05 On which of the following frequencies are General class licensees prohibited from operating as control operator?

7.125 MHz to 7.175 MHz

G1A06 Which of the following applies when the FCC rules designate the amateur service as a secondary user on a band?

Amateur stations must not cause harmful interference to primary users and must accept interference from primary users

G1A07 On which amateur frequencies in the 10-meter band may stations with a General class control operator transmit CW emissions?

The entire band

G1A08 Which HF bands have segments exclusively allocated to Amateur Extra licensees?

80 meters, 40 meters, 20 meters, and 15 meters

G1A09 Which of the following frequencies is within the General class portion of the 15-meter band?

21300 kHz

G1A10 What portion of the 10-meter band is available for repeater use?

The portion above 29.5 MHz

G1A11 When General class licensees are not permitted to use the entire voice portion of a band, which portion of the voice segment is available to them?

The upper frequency portion

G1B – Antenna structure limitations; good engineering and good amateur practice; beacon operation; prohibited transmissions; retransmitting radio signals

G1B01 What is the maximum height above ground for an antenna structure not near a public use airport without requiring notification to the FAA and registration with the FCC?

200 feet

G1B02 With which of the following conditions must beacon stations comply?

No more than one beacon station may transmit in the same band from the same station location

G1B03 Which of the following is a purpose of a beacon station as identified in the FCC rules?

Observation of propagation and reception

G1B04 Which of the following transmissions is permitted for all amateur stations?

Occasional retransmission of weather and propagation forecast information from US government stations

G1B05 Which of the following one-way transmissions are permitted?

Transmissions to assist with learning the International Morse code

G1B06 Under what conditions are state and local governments permitted to regulate amateur radio antenna structures?

Amateur Service communications must be reasonably accommodated, and regulations must constitute the minimum practical to accommodate a legitimate purpose of the state or local entity

G1B07 What are the restrictions on the use of abbreviations or procedural signals in the amateur service?

They may be used if they do not obscure the meaning of a message

G1B08 When is it permissible to communicate with amateur stations in countries outside the areas administered by the Federal Communications Commission?

When the contact is with amateurs in any country except those whose administrations have notified the ITU that they object to such communications

G1B09 On what HF frequencies are automatically controlled beacons permitted?

28.20 MHz to 28.30 MHz

G1B10 What is the power limit for beacon stations?

100 watts PEP output

G1B11 Who or what determines “good engineering and good amateur practice,” as applied to the operation of an amateur station in all respects not covered by the Part 97 rules?

The FCC

G1C – Transmitter power regulations; data emission standards; 60-meter operation requirements

G1C01 What is the maximum transmitter power an amateur station may use on 10.140 MHz?

200 watts PEP output

G1C02 What is the maximum transmitter power an amateur station may use on the 12-meter band?

1500 watts PEP output

G1C03 What is the maximum bandwidth permitted by FCC rules for amateur radio stations transmitting on USB frequencies in the 60-meter band?

2.8 kHz

G1C04 Which of the following is required by the FCC rules when operating in the 60-meter band?

If you are using an antenna other than a dipole, you must keep a record of the gain of your antenna

G1C05 What is the limit for transmitter power on the 28 MHz band for a General Class control operator?

1500 watts PEP output

G1C06 What is the limit for transmitter power on the 1.8 MHz band?

1500 watts PEP output

G1C07 What must be done before using a new digital protocol on the air?

Publicly document the technical characteristics of the protocol

General Quick Study Guide 2023-2027

G1C08

DELETED

G1C09 What is the maximum power limit on the 60-meter band?

ERP of 100 watts PEP with respect to a dipole

G1C10

DELETED

G1C11 What measurement is specified by FCC rules that regulate maximum power?

PEP output from the transmitter

G1D – Volunteer Examiners and Volunteer Examiner Coordinators; temporary identification; element credit; remote operation

G1D01 Who may receive partial credit for the elements represented by an expired amateur radio license?

Any person who can demonstrate that they once held an FCC-issued General, Advanced, or Amateur Extra class license that was not revoked by the FCC

G1D02 What license examinations may you administer as an accredited Volunteer Examiner holding a General class operator license?

Technician only

G1D03 On which of the following band segments may you operate if you are a Technician class operator and have an unexpired Certificate of Successful Completion of Examination (CSCE) for General class privileges?

On any General or Technician class band segment

G1D04 Who must observe the administration of a Technician class license examination?

At least three Volunteer Examiners of General class or higher

G1D05 When operating a US station by remote control from outside the country, what license is required of the control operator?

A US operator/primary station license

G1D06 Until an upgrade to General class is shown in the FCC database, when must a Technician licensee identify with “AG” after their call sign?

Whenever they operate using General class frequency privileges

G1D07 Volunteer Examiners are accredited by what organization?

A Volunteer Examiner Coordinator

G1D08 Which of the following criteria must be met for a non-US citizen to be an accredited Volunteer Examiner?

The person must hold an FCC granted amateur radio license of General class or above

G1D09 How long is a Certificate of Successful Completion of Examination (CSCE) valid for exam element credit?

365 days

G1D10 What is the minimum age that one must be to qualify as an accredited Volunteer Examiner?

18 years

G1D11 What action is required to obtain a new General class license after a previously held license has expired and the two-year grace period has passed?

The applicant must show proof of the appropriate expired license grant and pass the current Element 2 exam

G1D12 When operating a station in South America by remote control over the internet from the US, what regulations apply?

Only those of the remote station’s country

G1E – Control categories; repeater regulations; third-party rules; ITU regions; automatically controlled digital station

G1E01 Which of the following would disqualify a third party from participating in sending a message via an amateur station?

The third party’s amateur license has been revoked and not reinstated

G1E02 When may a 10-meter repeater retransmit the 2-meter signal from a station that has a Technician class control operator?

Only if the 10-meter repeater control operator holds at least a General class license

G1E03 What is required to conduct communications with a digital station operating under automatic control outside the automatic control band segments?

The station initiating the contact must be under local or remote control

G1E04 Which of the following conditions require a licensed amateur radio operator to take specific steps to avoid harmful interference to other users or facilities?

All these choices are correct

- When operating within one mile of an FCC Monitoring Station
- When using a band where the Amateur Service is secondary
- When a station is transmitting spread spectrum emissions

G1E05 What are the restrictions on messages sent to a third party in a country with which there is a Third-Party Agreement?

They must relate to amateur radio, or remarks of a personal character, or messages relating to emergencies or disaster relief

G1E06 The frequency allocations of which ITU region apply to radio amateurs operating in North and South America?

Region 2

G1E07 In what part of the 2.4 GHz band may an amateur station communicate with non-licensed Wi-Fi stations?

No part

G1E08 What is the maximum PEP output allowed for spread spectrum transmissions?

10 watts

G1E09

DELETED

G1E10 Why should an amateur operator normally avoid transmitting on 14.100, 18.110, 21.150, 24.930 and 28.200 MHz?

A system of propagation beacon stations operates on those frequencies

G1E11 On what bands may automatically controlled stations transmitting RTTY or data emissions communicate with other automatically controlled digital stations?

Anywhere in the 6-meter or shorter wavelength bands, and in limited segments of some of the HF bands

G1E12 When may third-party messages be transmitted via remote control?

Under any circumstances in which third party messages are permitted by FCC rules

General Quick Study Guide 2023-2027

SUBELEMENT G2 OPERATING PROCEDURES

[5 Exam Questions – 5 Groups]

G2A – Phone operating procedures: USB/LSB conventions, breaking into a contact, transmitter setup for voice operation; answering DX stations

G2A01 Which mode is most commonly used for voice communications on frequencies of 14 MHz or higher?

Upper sideband

G2A02 Which mode is most commonly used for voice communications on the 160-, 75-, and 40-meter bands?

Lower sideband

G2A03 Which mode is most commonly used for SSB voice communications in the VHF and UHF bands?

Upper sideband

G2A04 Which mode is most commonly used for voice communications on the 17- and 12-meter bands?

Upper sideband

G2A05 Which mode of voice communication is most commonly used on the HF amateur bands?

Single sideband

G2A06 Which of the following is an advantage of using single sideband, as compared to other analog voice modes on the HF amateur bands?

Less bandwidth used and greater power efficiency

G2A07 Which of the following statements is true of single sideband (SSB)?

Only one sideband is transmitted; the other sideband and carrier are suppressed

G2A08 What is the recommended way to break into a phone contact?

Say your call sign once

G2A09 Why do most amateur stations use lower sideband on the 160-, 75-, and 40-meter bands?

It is commonly accepted amateur practice

G2A10 Which of the following statements is true of VOX operation versus PTT operation?

It allows “hands free” operation

G2A11 Generally, who should respond to a station in the contiguous 48 states calling “CQ DX”?

Any stations outside the lower 48 states

G2A12 What control is typically adjusted for proper ALC setting on a single sideband transceiver?

Transmit audio or microphone gain

G2B – Operating effectively; band plans; drills and emergencies; RACES operation

G2B01 Which of the following is true concerning access to frequencies?

Except during emergencies, no amateur station has priority access to any frequency

G2B02 What is the first thing you should do if you are communicating with another amateur station and hear a station in distress break in?

Acknowledge the station in distress and determine what assistance may be needed

G2B03 What is good amateur practice if propagation changes during a contact creating interference from other stations using the frequency?

Attempt to resolve the interference problem with the other stations in a mutually acceptable manner

G2B04 When selecting a CW transmitting frequency, what minimum separation from other stations should be used to minimize interference to stations on adjacent frequencies?

150 Hz to 500 Hz

G2B05 When selecting an SSB transmitting frequency, what minimum separation should be used to minimize interference to stations on adjacent frequencies?

2 kHz to 3 kHz

G2B06 How can you avoid harmful interference on an apparently clear frequency before calling CQ on CW or phone?

Send “QRL?” on CW, followed by your call sign; or, if using phone, ask if the frequency is in use, followed by your call sign

G2B07 Which of the following complies with commonly accepted amateur practice when choosing a frequency on which to initiate a call?

Follow the voluntary band plan

G2B08 What is the voluntary band plan restriction for US stations transmitting within the 48 contiguous states in the 50.1 MHz to 50.125 MHz band segment?

Only contacts with stations not within the 48 contiguous states

G2B09 Who may be the control operator of an amateur station transmitting in RACES to assist relief operations during a disaster?

Only a person holding an FCC-issued amateur operator license

G2B10 Which of the following is good amateur practice for net management?

Have a backup frequency in case of interference or poor conditions

G2B11 How often may RACES training drills and tests be routinely conducted without special authorization?

No more than 1 hour per week

G2C – CW operating procedures and procedural signals; Q signals; full break-in

G2C01 Which of the following describes full break-in CW operation (QSK)?

Transmitting stations can receive between code characters and elements

G2C02 What should you do if a CW station sends “QRS?”

Send slower

G2C03 What does it mean when a CW operator sends “KN” at the end of a transmission?

Listening only for a specific station or stations

G2C04 What does the Q signal “QRL?” mean?

“Are you busy?” or “Is this frequency in use?”

G2C05 What is the best speed to use when answering a CQ in Morse code?

The fastest speed at which you are comfortable copying, but no faster than the CQ

G2C06 What does the term “zero beat” mean in CW operation?

Matching the transmit frequency to the frequency of a received signal

G2C07 When sending CW, what does a “C” mean when added to the RST report?

Chirp or unstable signal

G2C08 What prosign is sent to indicate the end of a formal message when using CW?

AR

G2C09 What does the Q signal “QSL” mean?

I have received and understood

G2C10 What does the Q signal “QRN” mean?

I am troubled by static

G2C11 What does the Q signal “QRV” mean?

I am ready to receive

G2D – Volunteer Monitor Program; HF operations

G2D01 What is the Volunteer Monitor Program?

Amateur volunteers who are formally enlisted to monitor the airwaves for rules violations

G2D02 Which of the following are objectives of the Volunteer Monitor Program?

To encourage amateur radio operators to self-regulate and comply with the rules

G2D03 What procedure may be used by Volunteer Monitors to localize a station whose continuous carrier is holding a repeater on in their area?

Compare beam headings on the repeater input from their home locations with that of other Volunteer Monitors

G2D04 Which of the following describes an azimuthal projection map?

A map that shows true bearings and distances from a specific location

G2D05 Which of the following indicates that you are looking for an HF contact with any station?

Repeat “CQ” a few times, followed by “this is,” then your call sign a few times, then pause to listen, repeat as necessary

G2D06 How is a directional antenna pointed when making a “long-path” contact with another station?

180 degrees from the station’s short-path heading

G2D07 Which of the following are examples of the NATO Phonetic Alphabet?

Alpha, Bravo, Charlie, Delta

G2D08 Why do many amateurs keep a station log?

To help with a reply if the FCC requests information about your station

General Quick Study Guide 2023-2027

G2D09 Which of the following is required when participating in a contest on HF frequencies?

Identify your station according to normal FCC regulations

G2D10 What is QRP operation?

Low-power transmit operation

G2D11 Why are signal reports typically exchanged at the beginning of an HF contact?

To allow each station to operate according to conditions

G2E – Digital mode operating procedures

G2E01 Which mode is normally used when sending RTTY signals via AFSK with an SSB transmitter?

LSB

G2E02 What is VARA?

A digital protocol used with Winlink

G2E03 What symptoms may result from other signals interfering with a PACTOR or VARA transmission?

All these choices are correct

- Frequent retries or timeouts
- Long pauses in message transmission
- Failure to establish a connection between stations

G2E04 Which of the following is good practice when choosing a transmitting frequency to answer a station calling CQ using FT8?

Find a clear frequency during the alternate time slot to the calling station

G2E05 What is the standard sideband for JT65, JT9, FT4, or FT8 digital signal when using AFSK?

USB

G2E06 What is the most common frequency shift for RTTY emissions in the amateur HF bands?

170 Hz

G2E07 Which of the following is required when using FT8?

Computer time accurate to within approximately 1 second

G2E08 In what segment of the 20-meter band are most digital mode operations commonly found?

Between 14.070 MHz and 14.100 MHz

G2E09 How do you join a contact between two stations using the PACTOR protocol?

Joining an existing contact is not possible, PACTOR connections are limited to two stations

G2E10 Which of the following is a way to establish contact with a digital messaging system gateway station?

Transmit a connect message on the station’s published frequency

G2E11 What is the primary purpose of an Amateur Radio Emergency Data Network (AREDN) mesh network?

To provide high-speed data services during an emergency or community event

G2E12 Which of the following describes Winlink?

All these choices are correct

- An amateur radio wireless network to send and receive email on the internet
- A form of Packet Radio
- A wireless network capable of both VHF and HF band operation

G2E13 What is another name for a Winlink Remote Message Server?

Gateway

G2E14 What could be wrong if you cannot decode an RTTY or other FSK signal even though it is apparently tuned in properly?

All these choices are correct

- The mark and space frequencies may be reversed
- You may have selected the wrong baud rate
- You may be listening on the wrong sideband

G2E15 Which of the following is a common location for FT8?

Approximately 14.074 MHz to 14.077 MHz

SUBELEMENT G3

RADIO WAVE PROPAGATION

[3 Exam Questions – 3 Groups]

G3A – Sunspots and solar radiation; geomagnetic field and stability indices

G3A01 How does a higher sunspot number affect HF propagation?

Higher sunspot numbers generally indicate a greater probability of good propagation at higher frequencies

General Quick Study Guide 2023-2027

G3A02 What effect does a sudden ionospheric disturbance have on the daytime ionospheric propagation?

It disrupts signals on lower frequencies more than those on higher frequencies

G3A03 Approximately how long does it take the increased ultraviolet and X-ray radiation from a solar flare to affect radio propagation on Earth?

8 minutes

G3A04 Which of the following are the least reliable bands for long-distance communications during periods of low solar activity?

15 meters, 12 meters, and 10 meters

G3A05 What is the solar flux index?

A measure of solar radiation with a wavelength of 10.7 centimeters

G3A06 What is a geomagnetic storm?

A temporary disturbance in Earth's geomagnetic field

G3A07 At what point in the solar cycle does the 20-meter band usually support worldwide propagation during daylight hours?

At any point

G3A08 How can a geomagnetic storm affect HF propagation?

Degrade high-latitude HF propagation

G3A09 How can high geomagnetic activity benefit radio communications?

Creates auroras that can reflect VHF signals

G3A10 What causes HF propagation conditions to vary periodically in a 26- to 28-day cycle?

Rotation of the Sun's surface layers around its axis

G3A11 How long does it take a coronal mass ejection to affect radio propagation on Earth?

15 hours to several days

G3A12 What does the K-index measure?

The short-term stability of Earth's geomagnetic field

G3A13 What does the A-index measure?

The long-term stability of Earth's geomagnetic field

G3A14 How is long distance radio communication usually affected by the charged particles that reach Earth from solar coronal holes?

HF communication is disturbed

G3B – Maximum Usable Frequency; Lowest Usable Frequency; short path and long path propagation; determining propagation conditions; ionospheric refraction

G3B01 What is a characteristic of skywave signals arriving at your location by both short-path and long-path propagation?

A slightly delayed echo might be heard

G3B02 What factors affect the MUF?

All these choices are correct

- Path distance and location
- Time of day and season
- Solar radiation and ionospheric disturbances

G3B03 Which frequency will have the least attenuation for long-distance skip propagation?

Just below the MUF

G3B04 Which of the following is a way to determine current propagation on a desired band from your station?

Use a network of automated receiving stations on the internet to see where your transmissions are being received

G3B05 How does the ionosphere affect radio waves with frequencies below the MUF and above the LUF?

They are refracted back to Earth

G3B06 What usually happens to radio waves with frequencies below the LUF?

They are attenuated before reaching the destination

G3B07 What does LUF stand for?

The Lowest Usable Frequency for communications between two specific points

G3B08 What does MUF stand for?

The Maximum Usable Frequency for communications between two points

G3B09 What is the approximate maximum distance along the Earth's surface normally covered in one hop using the F2 region?

2,500 miles

G3B10 What is the approximate maximum distance along the Earth's surface normally covered in one hop using the E region?

1,200 miles

G3B11 What happens to HF propagation when the LUF exceeds the MUF?

Propagation via ordinary skywave communications is not possible over that path

G3B12 Which of the following is typical of the lower HF frequencies during the summer?

High levels of atmospheric noise or static

G3C – Ionospheric regions; critical angle and frequency; HF scatter; near vertical incidence skywave (NVIS)

G3C01 Which ionospheric region is closest to the surface of Earth?

The D region

G3C02 What is meant by the term "critical frequency" at a given incidence angle?

The highest frequency which is refracted back to Earth

G3C03 Why is skip propagation via the F2 region longer than that via the other ionospheric regions?

Because it is the highest

G3C04 What does the term "critical angle" mean, as applied to radio wave propagation?

The highest takeoff angle that will return a radio wave to Earth under specific ionospheric conditions

G3C05 Why is long-distance communication on the 40-, 60-, 80-, and 160-meter bands more difficult during the day?

The D region absorbs signals at these frequencies during daylight hours

G3C06 What is a characteristic of HF scatter?

Signals have a fluttering sound

G3C07 What makes HF scatter signals often sound distorted?

Energy is scattered into the skip zone through several different paths

G3C08 Why are HF scatter signals in the skip zone usually weak?

Only a small part of the signal energy is scattered into the skip zone

General Quick Study Guide 2023-2027

G3C09 What type of propagation allows signals to be heard in the transmitting station's skip zone?

Scatter

G3C10 What is near vertical incidence skywave (NVIS) propagation?

Short distance MF or HF propagation at high elevation angles

G3C11 Which ionospheric region is the most absorbent of signals below 10 MHz during daylight hours?

The D region

SUBELEMENT G4 AMATEUR RADIO PRACTICES

[5 Exam Questions – 5 groups]

G4A – Station configuration and operation

G4A01 What is the purpose of the notch filter found on many HF transceivers?

To reduce interference from carriers in the receiver passband

G4A02 What is the benefit of using the opposite or "reverse" sideband when receiving CW?

It may be possible to reduce or eliminate interference from other signals

G4A03 How does a noise blanker work?

By reducing receiver gain during a noise pulse

G4A04 What is the effect on plate current of the correct setting of a vacuum-tube RF power amplifier's TUNE control?

A pronounced dip

G4A05 Why is automatic level control (ALC) used with an RF power amplifier?

To prevent excessive drive

G4A06 What is the purpose of an antenna tuner?

Increase power transfer from the transmitter to the feed line

G4A07 What happens as a receiver's noise reduction control level is increased?

Received signals may become distorted

G4A08 What is the correct adjustment for the LOAD or COUPLING control of a vacuum tube RF power amplifier?

Desired power output without exceeding maximum allowable plate current

G4A09 What is the purpose of delaying RF output after activating a transmitter's keying line to an external amplifier?

To allow time for the amplifier to switch the antenna between the transceiver and the amplifier output

G4A10 What is the function of an electronic keyer?

Automatic generation of dots and dashes for CW operation

G4A11 Why should the ALC system be inactive when transmitting AFSK data signals?

The ALC action distorts the signal

G4A12 Which of the following is a common use of the dual-VFO feature on a transceiver?

To transmit on one frequency and listen on another

G4A13 What is the purpose of using a receive attenuator?

To prevent receiver overload from strong incoming signals

G4B – Tests and test equipment

G4B01 What item of test equipment contains horizontal and vertical channel amplifiers?

An oscilloscope

G4B02 Which of the following is an advantage of an oscilloscope versus a digital voltmeter?

Complex waveforms can be measured

G4B03 Which of the following is the best instrument to use for checking the keying waveform of a CW transmitter?

An oscilloscope

G4B04 What signal source is connected to the vertical input of an oscilloscope when checking the RF envelope pattern of a transmitted signal?

The attenuated RF output of the transmitter

G4B05 Why do voltmeters have high input impedance?

It decreases the loading on circuits being measured

G4B06 What is an advantage of a digital multimeter as compared to an analog multimeter?

Higher precision

G4B07 What signals are used to conduct a two-tone test?

Two non-harmonically related audio signals

G4B08 What transmitter performance parameter does a two-tone test analyze?

Linearity

G4B09 When is an analog multimeter preferred to a digital multimeter?

When adjusting circuits for maximum or minimum values

G4B10 Which of the following can be determined with a directional wattmeter?

Standing wave ratio

G4B11 Which of the following must be connected to an antenna analyzer when it is being used for SWR measurements?

Antenna and feed line

G4B12 What effect can strong signals from nearby transmitters have on an antenna analyzer?

Received power that interferes with SWR readings

G4B13 Which of the following can be measured with an antenna analyzer?

Impedance of coaxial cable

G4C – Interference to consumer electronics; grounding and bonding

G4C01 Which of the following might be useful in reducing RF interference to audio frequency circuits?

Bypass capacitor

G4C02 Which of the following could be a cause of interference covering a wide range of frequencies?

Arcing at a poor electrical connection

G4C03 What sound is heard from an audio device experiencing RF interference from a single sideband phone transmitter?

Distorted speech

G4C04 What sound is heard from an audio device experiencing RF interference from a CW transmitter?

On-and-off humming or clicking

G4C05 What is a possible cause of high voltages that produce RF burns?

The ground wire has high impedance on that frequency

General Quick Study Guide 2023-2027

G4C06 What is a possible effect of a resonant ground connection?

High RF voltages on the enclosures of station equipment

G4C07 Why should soldered joints not be used in lightning protection ground connections?

A soldered joint will likely be destroyed by the heat of a lightning strike

G4C08 Which of the following would reduce RF interference caused by common-mode current on an audio cable?

Place a ferrite choke on the cable

G4C09 How can the effects of ground loops be minimized?

Bond equipment enclosures together

G4C10 What could be a symptom caused by a ground loop in your station's audio connections?

You receive reports of "hum" on your station's transmitted signal

G4C11 What technique helps to minimize RF "hot spots" in an amateur station?

Bonding all equipment enclosures together

G4C12 Why must all metal enclosures of station equipment be grounded?

It ensures that hazardous voltages cannot appear on the chassis

G4D – Speech processors; S meters; sideband operation near band edges

G4D01 What is the purpose of a speech processor in a transceiver?

Increase the apparent loudness of transmitted voice signals

G4D02 How does a speech processor affect a single sideband phone signal?

It increases average power

G4D03 What is the effect of an incorrectly adjusted speech processor?

All these choices are correct

- Distorted speech
- Excess intermodulation products
- Excessive background noise

G4D04 What does an S meter measure?

Received signal strength

G4D05 How does a signal that reads 20 dB over S9 compare to one that reads S9 on a receiver, assuming a properly calibrated S meter?

It is 100 times more powerful

G4D06 How much change in signal strength is typically represented by one S unit?

6 dB

G4D07 How much must the power output of a transmitter be raised to change the S meter reading on a distant receiver from S8 to S9?

Approximately 4 times

G4D08 What frequency range is occupied by a 3 kHz LSB signal when the displayed carrier frequency is set to 7.178 MHz?

7.175 MHz to 7.178 MHz

G4D09 What frequency range is occupied by a 3 kHz USB signal with the displayed carrier frequency set to 14.347 MHz?

14.347 MHz to 14.350 MHz

G4D10 How close to the lower edge of a band's phone segment should your displayed carrier frequency be when using 3 kHz wide LSB?

At least 3 kHz above the edge of the segment

G4D11 How close to the upper edge of a band's phone segment should your displayed carrier frequency be when using 3 kHz wide USB?

At least 3 kHz below the edge of the band

G4E – Mobile and portable HF stations; alternative energy source operation

G4E01 What is the purpose of a capacitance hat on a mobile antenna?

To electrically lengthen a physically short antenna

G4E02 What is the purpose of a corona ball on an HF mobile antenna?

To reduce RF voltage discharge from the tip of the antenna while transmitting

G4E03 Which of the following direct, fused power connections would be the best for a 100-watt HF mobile installation?

To the battery using heavy-gauge wire

G4E04 Why should DC power for a 100-watt HF transceiver not be supplied by a vehicle's auxiliary power socket?

The socket's wiring may be inadequate for the current drawn by the transceiver

G4E05 Which of the following most limits an HF mobile installation?

Efficiency of the electrically short antenna

G4E06 What is one disadvantage of using a shortened mobile antenna as opposed to a full-size antenna?

Operating bandwidth may be very limited

G4E07 Which of the following may cause receive interference to an HF transceiver installed in a vehicle?

All these choices are correct

- The battery charging system
- The fuel delivery system
- The control computers

G4E08 In what configuration are the individual cells in a solar panel connected together?

Series-parallel

G4E09 What is the approximate open-circuit voltage from a fully illuminated silicon photovoltaic cell?

0.5 VDC

G4E10 Why should a series diode be connected between a solar panel and a storage battery that is being charged by the panel?

To prevent discharge of the battery through the panel during times of low or no illumination

G4E11 What precaution should be taken when connecting a solar panel to a lithium iron phosphate battery?

The solar panel must have a charge controller

SUBELEMENT G5 ELECTRICAL PRINCIPLES

[3 Exam Questions – 3 Groups]

G5A – Reactance; inductance; capacitance; impedance; impedance transformation; resonance

G5A01 What happens when inductive and capacitive reactance are equal in a series LC circuit?

Resonance causes impedance to be very low

G5A02 What is reactance?

Opposition to the flow of alternating current caused by capacitance or inductance

General Quick Study Guide 2023-2027

G5A03 Which of the following is opposition to the flow of alternating current in an inductor?

Reactance

G5A04 Which of the following is opposition to the flow of alternating current in a capacitor?

Reactance

G5A05 How does an inductor react to AC?

As the frequency of the applied AC increases, the reactance increases

G5A06 How does a capacitor react to AC?

As the frequency of the applied AC increases, the reactance decreases

G5A07 What is the term for the inverse of impedance?

Admittance

G5A08 What is impedance?

The ratio of voltage to current

G5A09 What unit is used to measure reactance?

Ohm

G5A10 (D)

Which of the following devices can be used for impedance matching at radio frequencies?

All these choices are correct

- A transformer
- A Pi-network
- A length of transmission line

G5A11 What letter is used to represent reactance?

X

G5A12 What occurs in an LC circuit at resonance?

Inductive reactance and capacitive reactance cancel

G5B – The decibel; current and voltage dividers; electrical power calculations; sine wave root-mean-square (RMS) values; PEP calculations

G5B01 What dB change represents a factor of two increase or decrease in power?

Approximately 3 dB

G5B02 How does the total current relate to the individual currents in a circuit of parallel resistors?

It equals the sum of the currents through each branch

G5B03 How many watts of electrical power are consumed if 400 VDC is supplied to an 800-ohm load?

200 watts

G5B04 How many watts of electrical power are consumed by a 12 VDC light bulb that draws 0.2 amperes?

2.4 watts

G5B05 How many watts are consumed when a current of 7.0 milliamperes flows through a 1,250-ohm resistance?

Approximately 61 milliwatts

G5B06 What is the PEP produced by 200 volts peak-to-peak across a 50-ohm dummy load?

100 watts

G5B07 What value of an AC signal produces the same power dissipation in a resistor as a DC voltage of the same value?

The RMS value

G5B08 What is the peak-to-peak voltage of a sine wave with an RMS voltage of 120 volts?

339.4 volts

G5B09 What is the RMS voltage of a sine wave with a value of 17 volts peak?

12 volts

G5B10 What percentage of power loss is equivalent to a loss of 1 dB?

20.6 percent

G5B11 What is the ratio of PEP to average power for an unmodulated carrier?

1.00

G5B12 What is the RMS voltage across a 50-ohm dummy load dissipating 1200 watts?

245 volts

G5B13 What is the output PEP of an unmodulated carrier if the average power is 1060 watts?

1060 watts

G5B14 What is the output PEP of 500 volts peak-to-peak across a 50-ohm load?

625 watts

G5C – Resistors, capacitors, and inductors in series and parallel; transformers

G5C01 What causes a voltage to appear across the secondary winding of a transformer when an AC voltage source is connected across its primary winding?

Mutual inductance

G5C02 What is the output voltage if an input signal is applied to the secondary winding of a 4:1 voltage step-down transformer instead of the primary winding?

The input voltage is multiplied by 4

G5C03 What is the total resistance of a 10-, a 20-, and a 50-ohm resistor connected in parallel?

5.9 ohms

G5C04 What is the approximate total resistance of a 100- and a 200-ohm resistor in parallel?

67 ohms

G5C05 Why is the primary winding wire of a voltage step-up transformer usually a larger size than that of the secondary winding?

To accommodate the higher current of the primary

G5C06 What is the voltage output of a transformer with a 500-turn primary and a 1500-turn secondary when 120 VAC is applied to the primary?

360 volts

G5C07 What transformer turns ratio matches an antenna's 600-ohm feed point impedance to a 50-ohm coaxial cable?

3.5 to 1

G5C08 What is the equivalent capacitance of two 5.0-nanofarad capacitors and one 750-picofarad capacitor connected in parallel?

10.750 nanofarads

G5C09 What is the capacitance of three 100-microfarad capacitors connected in series?

33.3 microfarads

G5C10 What is the inductance of three 10-millihenry inductors connected in parallel?

3.3 millihenries

G5C11 What is the inductance of a circuit with a 20-millihenry inductor connected in series with a 50-millihenry inductor?

70 millihenries

G5C12 What is the capacitance of a 20-microfarad capacitor connected in series with a 50-microfarad capacitor?

14.3 microfarads

G5C13 Which of the following components should be added to a capacitor to increase the capacitance?

A capacitor in parallel

General Quick Study Guide 2023-2027

G5C14 Which of the following components should be added to an inductor to increase the inductance?

An inductor in series

**SUBELEMENT G6
CIRCUIT COMPONENTS**

[2 Exam Questions – 2 Groups]

G6A – Resistors; capacitors; inductors; rectifiers; solid-state diodes and transistors; vacuum tubes; batteries

G6A01 What is the minimum allowable discharge voltage for maximum life of a standard 12-volt lead-acid battery?

10.5 volts

G6A02 What is an advantage of batteries with low internal resistance?

High discharge current

G6A03 What is the approximate forward threshold voltage of a germanium diode?

0.3 volts

G6A04 Which of the following is characteristic of an electrolytic capacitor?

High capacitance for a given volume

G6A05 What is the approximate forward threshold voltage of a silicon junction diode?

0.7 volts

G6A06 Why should wire-wound resistors not be used in RF circuits?

The resistor’s inductance could make circuit performance unpredictable

G6A07 What are the operating points for a bipolar transistor used as a switch?

Saturation and cutoff

G6A08 Which of the following is characteristic of low voltage ceramic capacitors?

Comparatively low cost

G6A09 Which of the following describes MOSFET construction?

The gate is separated from the channel by a thin insulating layer

G6A10 Which element of a vacuum tube regulates the flow of electrons between cathode and plate?

Control grid

G6A11 What happens when an inductor is operated above its self-resonant frequency?

It becomes capacitive

G6A12 What is the primary purpose of a screen grid in a vacuum tube?

To reduce grid-to-plate capacitance

G6B – Analog and digital integrated circuits (ICs); microwave ICs (MMICs); display devices; RF connectors; ferrite cores

G6B01 What determines the performance of a ferrite core at different frequencies?

The composition, or “mix,” of materials used

G6B02 What is meant by the term MMIC?

Monolithic Microwave Integrated Circuit

G6B03 Which of the following is an advantage of CMOS integrated circuits compared to TTL integrated circuits?

Low power consumption

G6B04 What is a typical upper frequency limit for low SWR operation of 50-ohm BNC connectors?

4 GHz

G6B05 What is an advantage of using a ferrite core toroidal inductor?

All these choices are correct

- Large values of inductance may be obtained
- The magnetic properties of the core may be optimized for a specific range of frequencies
- Most of the magnetic field is contained in the core

G6B06 What kind of device is an integrated circuit operational amplifier?

Analog

G6B07 Which of the following describes a type N connector?

A moisture-resistant RF connector useful to 10 GHz

G6B08 How is an LED biased when emitting light?

Forward biased

G6B09

DELETED

G6B10 How does a ferrite bead or core reduce common-mode RF current on the shield of a coaxial cable?

By creating an impedance in the current’s path

G6B11 What is an SMA connector?

A small threaded connector suitable for signals up to several GHz

G6B12 Which of these connector types is commonly used for low frequency or dc signal connections to a transceiver?

RCA Phono

**SUBELEMENT G7
PRACTICAL CIRCUITS**

[3 Exam Questions – 3 Groups]

G7A – Power supplies; schematic symbols

G7A01 What is the function of a power supply bleeder resistor?

It discharges the filter capacitors when power is removed

G7A02 Which of the following components are used in a power supply filter network?

Capacitors and inductors

G7A03 Which type of rectifier circuit uses two diodes and a center-tapped transformer?

Full-wave

G7A04 What is characteristic of a half-wave rectifier in a power supply?

Only one diode is required

G7A05 What portion of the AC cycle is converted to DC by a half-wave rectifier?

180 degrees

G7A06 What portion of the AC cycle is converted to DC by a full-wave rectifier?

360 degrees

G7A07 What is the output waveform of an unfiltered full-wave rectifier connected to a resistive load?

A series of DC pulses at twice the frequency of the AC input

G7A08 Which of the following is characteristic of a switchmode power supply as compared to a linear power supply?

High-frequency operation allows the use of smaller components

G8A02 What is the name of the process that changes the phase angle of an RF signal to convey information?

Phase modulation

G8A03 What is the name of the process that changes the instantaneous frequency of an RF wave to convey information?

Frequency modulation

G8A04 What emission is produced by a reactance modulator connected to a transmitter RF amplifier stage?

Phase modulation

G8A05 What type of modulation varies the instantaneous power level of the RF signal?

Amplitude modulation

G8A06 Which of the following is characteristic of QPSK31?

All these choices are correct

- It is sideband sensitive
- Its encoding provides error correction
- Its bandwidth is approximately the same as BPSK31

G8A07 Which of the following phone emissions uses the narrowest bandwidth?

Single sideband

G8A08 Which of the following is an effect of overmodulation?

Excessive bandwidth

G8A09 What type of modulation is used by FT8?

8-tone frequency shift keying

G8A10 What is meant by the term “flat-topping,” when referring to an amplitude-modulated phone signal?

Signal distortion caused by excessive drive or speech levels

G8A11 What is the modulation envelope of an AM signal?

The waveform created by connecting the peak values of the modulated signal

G8A12 What is QPSK modulation?

Modulation in which digital data is transmitted using 0-, 90-, 180- and 270-degree phase shift to represent pairs of bits

G8A13 What is a link budget?

The sum of transmit power and antenna gains minus system losses as seen at the receiver

G8A14 What is link margin?

The difference between received power level and minimum required signal level at the input to the receiver

G8B – Frequency changing; bandwidths of various modes; deviation; intermodulation

G8B01 Which mixer input is varied or tuned to convert signals of different frequencies to an intermediate frequency (IF)?

Local oscillator

G8B02 What is the term for interference from a signal at twice the IF frequency from the desired signal?

Image response

G8B03 What is another term for the mixing of two RF signals?

Heterodyning

G8B04 What is the stage in a VHF FM transmitter that generates a harmonic of a lower frequency signal to reach the desired operating frequency?

Multiplier

G8B05 Which intermodulation products are closest to the original signal frequencies?

Odd-order

G8B06 What is the total bandwidth of an FM phone transmission having 5 kHz deviation and 3 kHz modulating frequency?

16 kHz

G8B07 What is the frequency deviation for a 12.21 MHz reactance modulated oscillator in a 5 kHz deviation, 146.52 MHz FM phone transmitter?

416.7 Hz

G8B08 Why is it important to know the duty cycle of the mode you are using when transmitting?

Some modes have high duty cycles that could exceed the transmitter’s average power rating

G8B09 Why is it good to match receiver bandwidth to the bandwidth of the operating mode?

It results in the best signal-to-noise ratio

G8B10 What is the relationship between transmitted symbol rate and bandwidth?

Higher symbol rates require wider bandwidth

G8B11 What combination of a mixer’s Local Oscillator (LO) and RF input frequencies is found in the output?

The sum and difference

G8B12 What process combines two signals in a non-linear circuit to produce unwanted spurious outputs?

Intermodulation

G8B13 Which of the following is an odd-order intermodulation product of frequencies F1 and F2?

2F1-F2

G8C01 On what band do amateurs share channels with the unlicensed Wi-Fi service?

2.4 GHz

G8C02 Which digital mode is used as a low-power beacon for assessing HF propagation?

WSPR

G8C03 What part of a packet radio frame contains the routing and handling information?

Header

G8C04 Which of the following describes Baudot code?

A 5-bit code with additional start and stop bits

G8C05 In an ARQ mode, what is meant by a NAK response to a transmitted packet?

Request retransmission of the packet

G8C06 What action results from a failure to exchange information due to excessive transmission attempts when using an ARQ mode?

The connection is dropped

G8C07 Which of the following narrow-band digital modes can receive signals with very low signal-to-noise ratios?

FT8

G8C08 Which of the following statements is true about PSK31?

Upper case letters use longer Varicode bit sequences and thus slow down transmission

G8C09 Which is true of mesh network microwave nodes?

If one node fails, a packet may still reach its target station via an alternate node

General Quick Study Guide 2023-2027

G8C10 How does forward error correction (FEC) allow the receiver to correct data errors?

By transmitting redundant information with the data

G8C11 How are the two separate frequencies of a Frequency Shift Keyed (FSK) signal identified?

Mark and space

G8C12 Which type of code is used for sending characters in a PSK31 signal?

Varicode

G8C13 What is indicated on a waterfall display by one or more vertical lines on either side of a data mode or RTTY signal?

Overmodulation

G8C14 Which of the following describes a waterfall display?

Frequency is horizontal, signal strength is intensity, time is vertical

G8C15 What does an FT8 signal report of +3 mean?

The signal-to-noise ratio is equivalent to +3dB in a 2.5 kHz bandwidth

G8C16 Which of the following provide digital voice modes?

DMR, D-STAR, and System Fusion

SUBELEMENT G9

ANTENNAS AND FEED LINES

[4 Exam Questions – 4 Groups]

G9A – Feed lines: characteristic impedance and attenuation; standing wave ratio (SWR) calculation, measurement, and effects; antenna feed point matching

G9A01 Which of the following factors determine the characteristic impedance of a parallel conductor feed line?

The distance between the centers of the conductors and the radius of the conductors

G9A02 What is the relationship between high standing wave ratio (SWR) and transmission line loss?

High SWR increases loss in a lossy transmission line

G9A03 What is the nominal characteristic impedance of “window line” transmission line?

450 ohms

G9A04 What causes reflected power at an antenna’s feed point?

A difference between feed line impedance and antenna feed point impedance

G9A05 How does the attenuation of coaxial cable change with increasing frequency?

Attenuation increases

G9A06 In what units is RF feed line loss usually expressed?

Decibels per 100 feet

G9A07 What must be done to prevent standing waves on a feed line connected to an antenna?

The antenna feed point impedance must be matched to the characteristic impedance of the feed line

G9A08 If the SWR on an antenna feed line is 5:1, and a matching network at the transmitter end of the feed line is adjusted to present a 1:1 SWR to the transmitter, what is the resulting SWR on the feed line?

5:1

G9A09 What standing wave ratio results from connecting a 50-ohm feed line to a 200-ohm resistive load?

4:1

G9A10 What standing wave ratio results from connecting a 50-ohm feed line to a 10-ohm resistive load?

5:1

G9A11 What is the effect of transmission line loss on SWR measured at the input to the line?

Higher loss reduces SWR measured at the input to the line

G9B – Basic dipole and monopole antennas

G9B01 What is a characteristic of a random-wire HF antenna connected directly to the transmitter?

Station equipment may carry significant RF current

G9B02 Which of the following is a common way to adjust the feed point impedance of an elevated quarter-wave ground-plane vertical antenna to be approximately 50 ohms?

Slope the radials downward

G9B03 Which of the following best describes the radiation pattern of a quarter-wave ground-plane vertical antenna?

Omnidirectional in azimuth

G9B04 What is the radiation pattern of a dipole antenna in free space in a plane containing the conductor?

It is a figure-eight at right angles to the antenna

G9B05 How does antenna height affect the azimuthal radiation pattern of a horizontal dipole HF antenna at elevation angles higher than 45 degrees?

If the antenna is less than 1/2 wavelength high, the azimuthal pattern is almost omnidirectional

G9B06 Where should the radial wires of a ground-mounted vertical antenna system be placed?

On the surface or buried a few inches below the ground

G9B07 How does the feed point impedance of a horizontal 1/2 wave dipole antenna change as the antenna height is reduced to 1/10 wavelength above ground?

It steadily decreases

G9B08 How does the feed point impedance of a 1/2 wave dipole change as the feed point is moved from the center toward the ends?

It steadily increases

G9B09 Which of the following is an advantage of using a horizontally polarized antenna as compared to a vertically polarized HF antenna?

Lower ground losses

G9B10 What is the approximate length for a 1/2 wave dipole antenna cut for 14.250 MHz?

33 feet

G9B11 What is the approximate length for a 1/2 wave dipole antenna cut for 3.550 MHz?

132 feet

G9B12 What is the approximate length for a 1/4 wave monopole antenna cut for 28.5 MHz?

8 feet

G9C – Directional antennas

G9C01 Which of the following would increase the bandwidth of a Yagi antenna?

Larger-diameter elements

General Quick Study Guide 2023-2027

G9D – Specialized antenna types and applications

G9C02 What is the approximate length of the driven element of a Yagi antenna?

1/2 wavelength

G9C03 How do the lengths of a three-element Yagi reflector and director compare to that of the driven element?

The reflector is longer, and the director is shorter

G9C04 How does antenna gain in dBi compare to gain stated in dBd for the same antenna?

Gain in dBi is 2.15 dB higher

G9C05 What is the primary effect of increasing boom length and adding directors to a Yagi antenna?

Gain increases

G9C06

DELETED

G9C07 What does “front-to-back ratio” mean in reference to a Yagi antenna?

The power radiated in the major lobe compared to that in the opposite direction

G9C08 What is meant by the “main lobe” of a directive antenna?

The direction of maximum radiated field strength from the antenna

G9C09 In free space, how does the gain of two three-element, horizontally polarized Yagi antennas spaced vertically 1/2 wavelength apart typically compare to the gain of a single three-element Yagi?

Approximately 3 dB higher

G9C10 Which of the following can be adjusted to optimize forward gain, front-to-back ratio, or SWR bandwidth of a Yagi antenna?

All these choices are correct

- A. The physical length of the boom
- B. The number of elements on the boom
- C. The spacing of each element along the boom

G9C11 What is a beta or hairpin match?

A shorted transmission line stub placed at the feed point of a Yagi antenna to provide impedance matching

G9C12 Which of the following is a characteristic of using a gamma match with a Yagi antenna?

It does not require the driven element to be insulated from the boom

G9D01 Which of the following antenna types will be most effective as a near vertical incidence skywave (NVIS) antenna for short-skip communications on 40 meters during the day?

A horizontal dipole placed between 1/10 and 1/4 wavelength above the ground

G9D02 What is the feed point impedance of an end-fed half-wave antenna?

Very high

G9D03 In which direction is the maximum radiation from a VHF/UHF “halo” antenna?

Omnidirectional in the plane of the halo

G9D04 What is the primary function of antenna traps?

To enable multiband operation

G9D05 What is an advantage of vertically stacking horizontally polarized Yagi antennas?

It narrows the main lobe in elevation

G9D06 Which of the following is an advantage of a log-periodic antenna?

Wide bandwidth

G9D07 Which of the following describes a log-periodic antenna?

Element length and spacing vary logarithmically along the boom

G9D08 How does a “screwdriver” mobile antenna adjust its feed point impedance?

By varying the base loading inductance

G9D09 What is the primary use of a Beverage antenna?

Directional receiving for MF and low HF bands

G9D10 In which direction or directions does an electrically small loop (less than 1/10 wavelength in circumference) have nulls in its radiation pattern?

Broadside to the loop

G9D11 Which of the following is a disadvantage of multiband antennas?

They have poor harmonic rejection

G9D12 What is the common name of a dipole with a single central support?

Inverted V

G9D13

DELETED

SUBELEMENT G0

ELECTRICAL AND RF SAFETY

[2 Exam Questions – 2 Groups]

G0A – RF safety principles, rules, and guidelines; routine station evaluation

G0A01 What is one way that RF energy can affect human body tissue?

It heats body tissue

G0A02 (D)

Which of the following is used to determine RF exposure from a transmitted signal?

All these choices are correct

- Its duty cycle
- Its frequency
- Its power density

G0A03 How can you determine that your station complies with FCC RF exposure regulations?

All these choices are correct

- By calculation based on FCC OET Bulletin 65
- By calculation based on computer modeling
- By measurement of field strength using calibrated equipment

G0A04 What does “time averaging” mean when evaluating RF radiation exposure?

The total RF exposure averaged over a certain period

G0A05 What must you do if an evaluation of your station shows that the RF energy radiated by your station exceeds permissible limits for possible human absorption?

Take action to prevent human exposure to the excessive RF fields

G0A06 What must you do if your station fails to meet the FCC RF exposure exemption criteria?

Perform an RF Exposure Evaluation in accordance with FCC OET Bulletin 65

G0A07 What is the effect of modulation duty cycle on RF exposure?

A lower duty cycle permits greater power levels to be transmitted

General Quick Study Guide 2023-2027

G0A08 Which of the following steps must an amateur operator take to ensure compliance with RF safety regulations?

Perform a routine RF exposure evaluation and prevent access to any identified high exposure areas

G0A09 What type of instrument can be used to accurately measure an RF field strength?

A calibrated field strength meter with a calibrated antenna

G0A10 What should be done if evaluation shows that a neighbor might experience more than the allowable limit of RF exposure from the main lobe of a directional antenna?

Take precautions to ensure that the antenna cannot be pointed in their direction when they are present

G0A11 What precaution should be taken if you install an indoor transmitting antenna?

Make sure that MPE limits are not exceeded in occupied areas

G0A12 What stations are subject to the FCC rules on RF exposure?

All stations with a time-averaged transmission of more than one milliwatt

G0B – Station safety: electrical shock, grounding, fusing, interlocks, and wiring; antenna and tower safety

G0B01 Which wire or wires in a four-conductor 240 VAC circuit should be attached to fuses or circuit breakers?

Only the hot wires

G0B02 According to the National Electrical Code, what is the minimum wire size that may be used safely for wiring with a 20-ampere circuit breaker?

AWG number 12

G0B03 Which size of fuse or circuit breaker would be appropriate to use with a circuit that uses AWG number 14 wiring?

15 amperes

G0B04 Where should the station's lightning protection ground system be located?

Outside the building

G0B05 Which of the following conditions will cause a ground fault circuit interrupter (GFCI) to disconnect AC power?

Current flowing from one or more of the hot wires directly to ground

G0B06 Which of the following is covered by the National Electrical Code?

Electrical safety of the station

G0B07 Which of these choices should be observed when climbing a tower using a safety harness?

Confirm that the harness is rated for the weight of the climber and that it is within its allowable service life

G0B08 What should be done before climbing a tower that supports electrically powered devices?

Make sure all circuits that supply power to the tower are locked out and tagged

G0B09 Which of the following is true of an emergency generator installation?

The generator should be operated in a well-ventilated area

G0B10 Which of the following is a danger from lead-tin solder?

Lead can contaminate food if hands are not washed carefully after handling the solder

G0B11 Which of the following is required for lightning protection ground rods?

They must be bonded together with all other grounds

G0B12 What is the purpose of a power supply interlock?

To ensure that dangerous voltages are removed if the cabinet is opened

G0B13 Where should lightning arrestors be located?

Where the feed lines enter the building

~end of question pool text~

General License Class Formulas

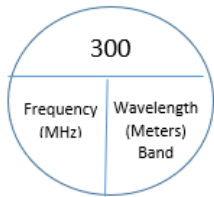

Band / Frequency Conversion

Band = 300 / Frequency

Frequency = 300 / Band

Approximately

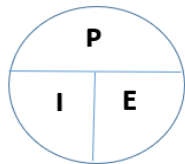

Power Equation

P = Power – Watts

I = Current – Amps

E = Volts – Voltage

$$P = I \times E$$

$$I = P / E$$

$$E = P / I$$

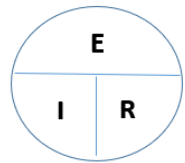

OHMs Law

E = Volts – Voltage

I = Current – Amps

R = Resistance – Ohms

$$E = I \times R$$

$$I = E / R$$

$$R = E / I$$

Other Equations

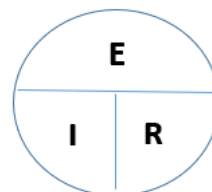
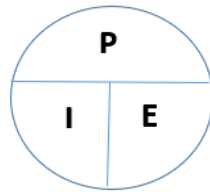

When the Power Equation or the OHM's Law formulas don't work because of missing information, combine them to find a solution.

- When looking for Watts and you only have Amps and Ohms, use:

$$P = I \times E$$

$$P = (E / R) \times E$$

$$P = E^2 / R$$

- When looking for Watts and you only have Volts and Ohms, use:

$$P = I \times E$$

$$P = I \times (E / R)$$

$$P = I^2 \times R$$

- When looking for Ohms and you only have Amps and Watts, use:

$$R = E / I$$

$$R = (P / I) / I$$

$$R = P / I^2$$

- When looking for Ohms and you only have Volts and Watts, use:

$$R = E / I$$

$$R = E / (P / E)$$

$$R = E^2 / P$$

NOTE: One graphic is required for certain questions in section G7.

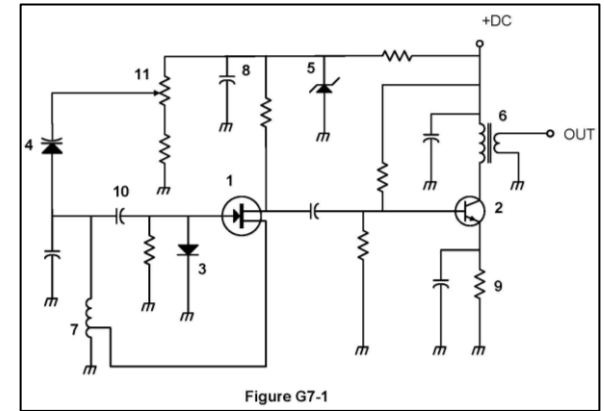
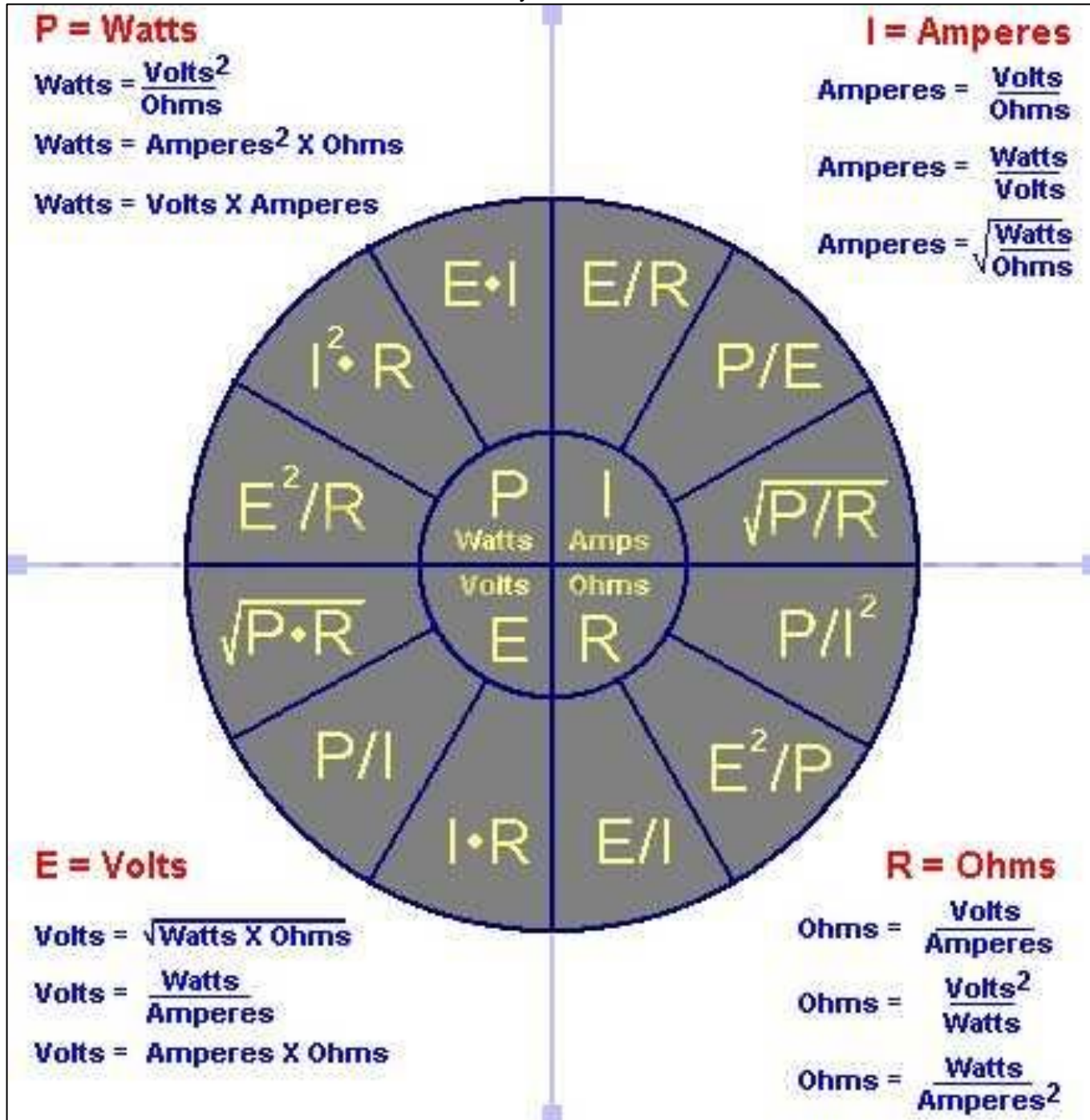

Figure G7-1



General Quick Study Guide 2023-2027
General License Class Abbreviations

AC – Alternating Current
AFSK - Audio Frequency Shift Keying
ALC- -Automatic Level Control
AM – Amplitude Modulation
AR – Indicates the end of a formal message in CW
AREDN - Amateur Radio Emergency Data Network
ARQ - Automatic Repeat Request
AWR – American Wire Research
BPSK - Binary Phase Shift Keying
C - Chirpy or unstable signal
CMOS - Complementary Metal-Oxide Semiconductor
CQ DX - Any stations outside the lower 48 states
CSCE - Certificate of Successful Completion of Examination
CW – Continuous Wave (Morse Code)
dB – Decibel
DC – Direct Current
DDS - Direct Digital Synthesizer
DSP - Digital Signal Processing
E - Electromotive Force (volts)
ERP – Effective Radiated Power
FAA – Federal Aviation Administration
FCC – Federal Communications Commission
FEC - Forward Error Correction
FM – Frequency Modulations
FSK – Frequency Shift Keying
GFCI - Ground Fault Circuit Interrupter
HF – High Frequency
I – Current Intensity (Amps)
IF - Intermediate Frequency

IQ - I - In-phase; Q – Quadrature
ITU – International Telecommunications Union
KN – Listening only for a specific station or stations
LC - Inductance Capacitance
LED – Light Emitting Diode
LO - Local Oscillator
LSB – Lower Sideband
LUF - The Lowest Usable Frequency
MF – Middle Frequency
MMIC - Monolithic Microwave Integrated Circuit
MPE - Maximum Permissible Exposure
MUF – Maximum Usable Frequency
NAK - Not Acknowledged
NATO – North Atlantic Treaty Organization
NVIS - Near Vertical Incidence Skywave
OET - Office of Engineering and Technology
P – Power (Watts)
PEP - Permissible Envelope Power
PTT - Push To Talk
PSK - Phase Shift Keying
Q – Quadrature
QPSK - Quadrature Phase Shift Keying
QRL – “Are you busy?” or “I am busy, please do not interfere”
QRN - I am troubled by static
QRP - Low-power transmit operation
QRS - Send slower
QRV - I am ready to receive
QSK – Full break-in Operation
QSL - I have received and understood
R - Resistance (ohms)

RF – Radio Frequency
RMS- Root Mean Square
RST - Readability-Strength-Tone
RTTY – Radio Teletype
SDR - Software-Defined Radio
SSB – Single Sideband
SWR - Standing Wave Ratio
TTL - Transistor-Transistor Logic
UHF – Ultra High Frequency
USB – Upper Sideband
VDC – Volts Direct Current
VE – Volunteer Examiner (Person)
VEC -Volunteer Examiner Coordinator (Organization)
VFO - Variable Frequency Oscillator
VHF – Very High Frequency
VOX - Voice Operating Transmit
WSJT - Weak Signal Joe Taylor
WSPR - (whisper) Weak Signal Propagation Reporter
X – Reactance