

# MAINTENANCE MANUAL SERVICE SECTION FOR HIGHBAND MVS COMBINATIONS

## TABLE OF CONTENTS

	<u>Page</u>
DESCRIPTION . . . . .	Front Cover
INITIAL ADJUSTMENT . . . . .	Front Cover
PREVENTIVE MAINTENANCE . . . . .	Front Cover
DISASSEMBLY PROCEDURE . . . . .	1
COMPONENT REPLACEMENT . . . . .	2
TROUBLESHOOTING PROCEDURE . . . . .	2
POWER DISTRIBUTION . . . . .	4
AUDIO SIGNAL FLOW . . . . .	4
LOGIC SIGNAL FLOW . . . . .	5

### DESCRIPTION

The Service Section contains the information necessary for aligning and troubleshooting the MVS two-way FM mobile radio. In addition, information is provided for disassembling the radio and replacing chip components.

### INITIAL ADJUSTMENT

After the radio has been installed as described in the Installation Manual, the following adjustments should be made by a certified electronics technician.

### TRANSMITTER ADJUSTMENT

The transmitter has been adjusted at the factory and should require no readjustment. However, the antenna length should be adjusted for optimum VSWR, and the frequency and modulation measured and recorded for future reference. For the complete transmitter alignment, refer to the Alignment Procedure (see Table of Contents).

### RECEIVER ADJUSTMENT

No initial adjustments to the receiver are required. Refer to the Table of Contents for the complete receiver alignment.

### RE-INSTALLATION

The MVS series mobile radios are designed to operate in 12 volt negative ground vehicles only. If the mobile radio is moved to a different vehicle, always check the battery polarity of the new vehicle system.

### PREVENTIVE MAINTENANCE

To ensure high operating efficiency and to prevent mechanical and electrical failures from interrupting system operations, routine checks should be made of all mechanical and electrical parts at regular intervals. Preventive maintenance should include the following checks:

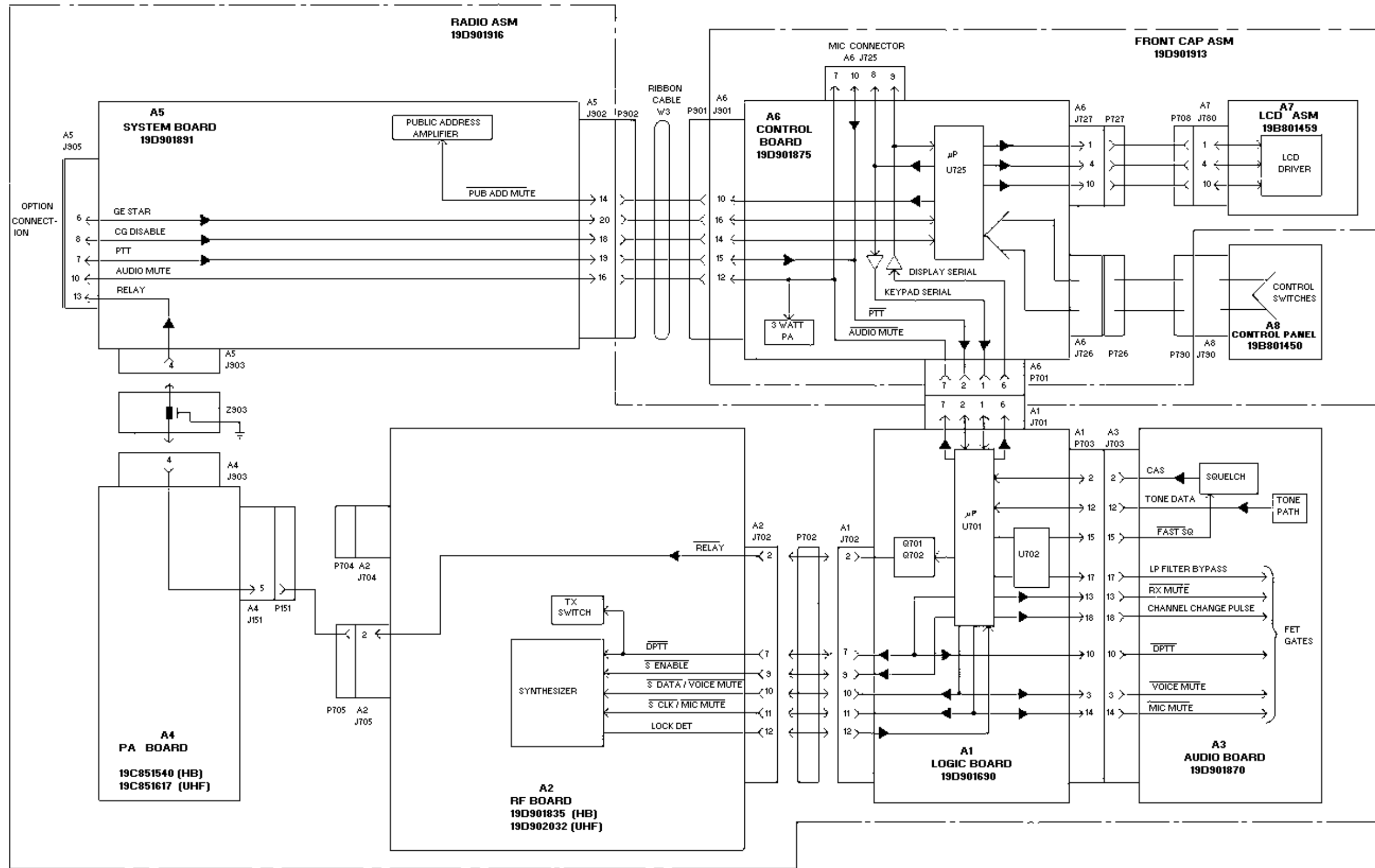
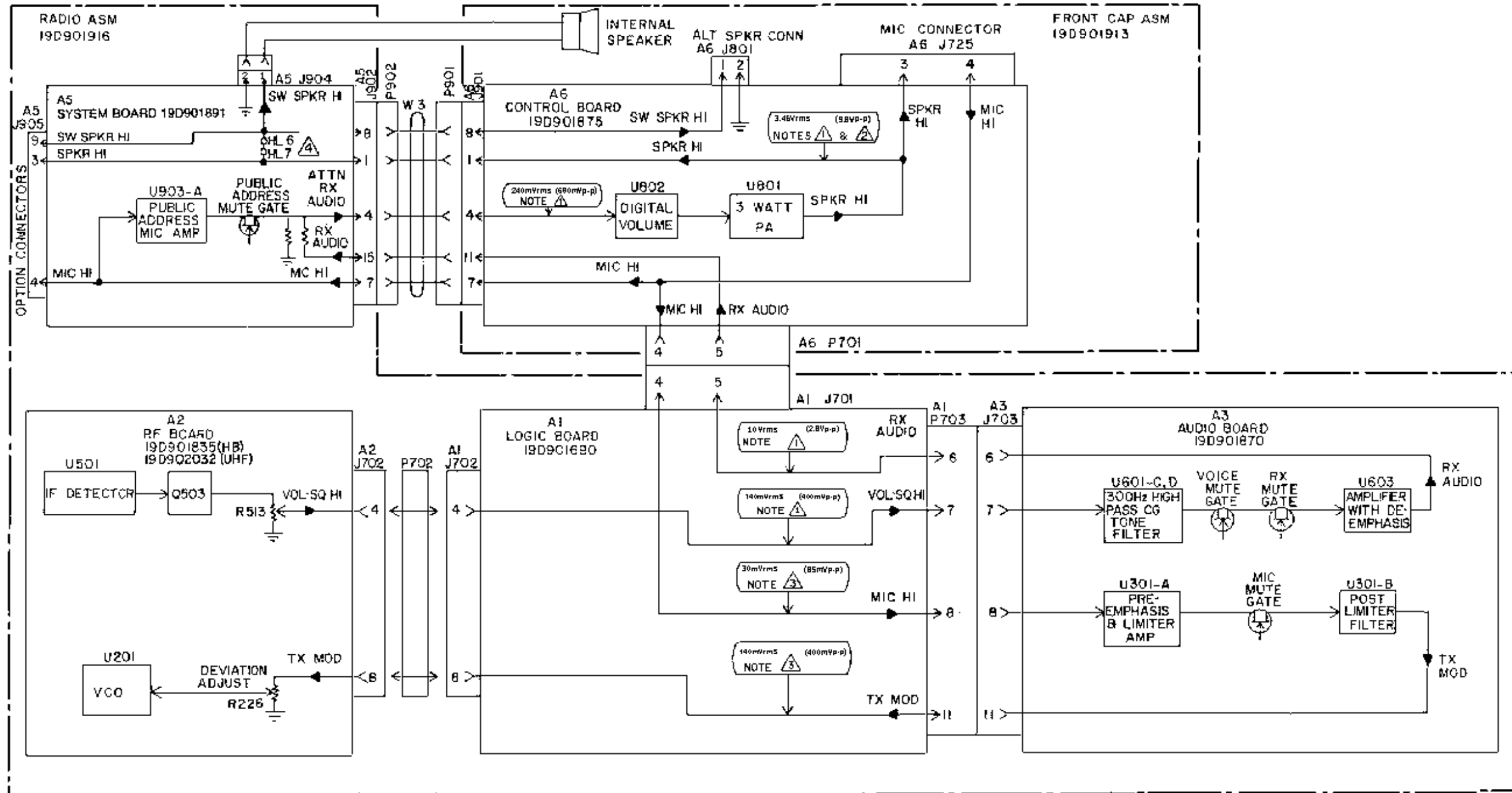
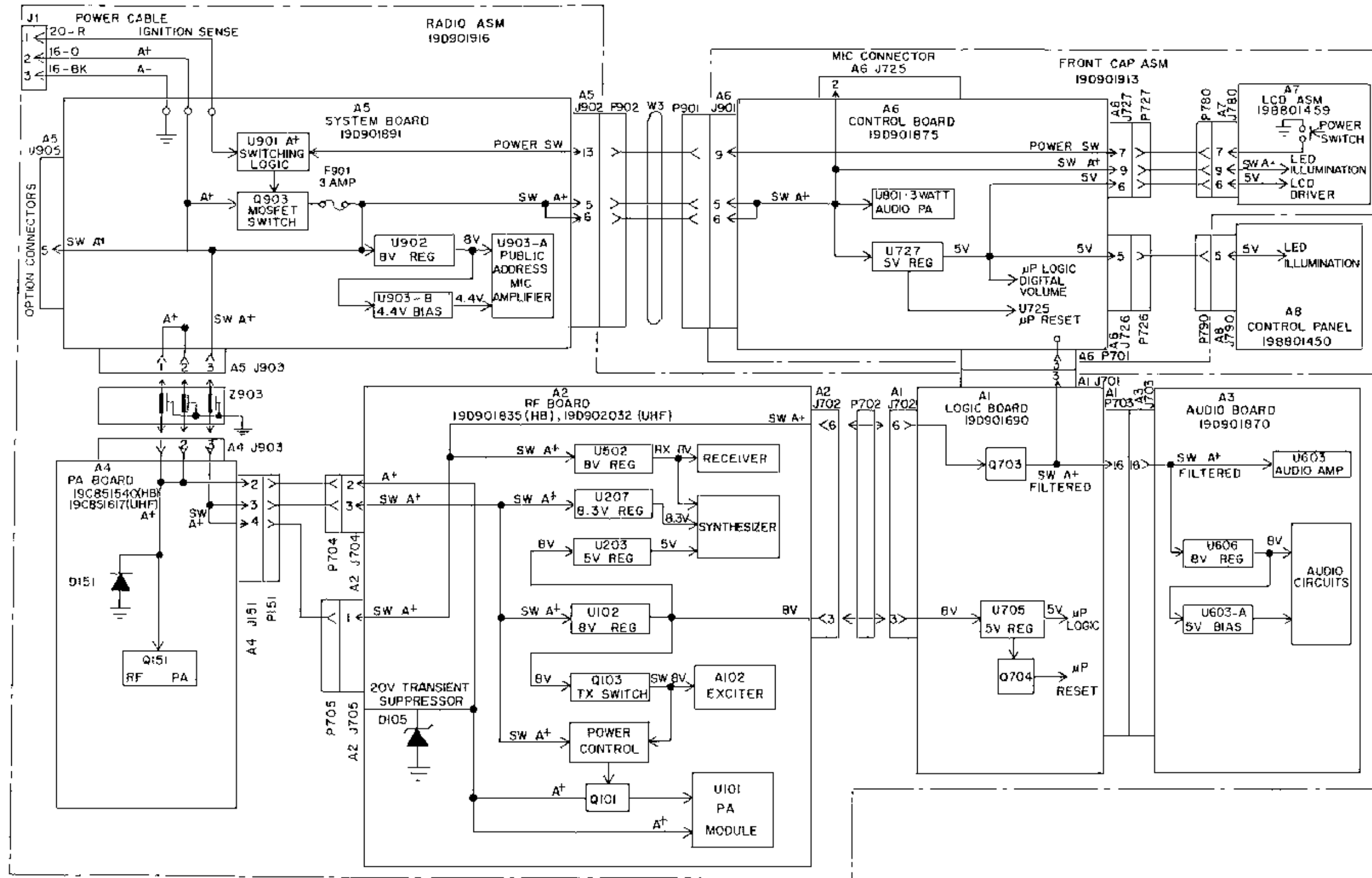

Figure 7 - Logic Signal Flow Block Diagram



- NOTES:
- ⚠️ RECEIVING A 1000 $\mu$ V ON-FREQUENCY SIGNAL MODULATED BY 1000 Hz AT  $\pm$ 3kHz DEVIATION.
  - ⚠️ VOLUME ADJUSTED FOR 3 WATTS OUTPUT.
  - ⚠️ AUDIO GENERATOR APPLIED TO MIC HI AND ADJUSTED FOR 30mVrms AT 1000 Hz.
  - ⚠️ CUT RUN BETWEEN HOLES 6 AND 7 TO DISABLE INTERNAL SPEAKER.

Figure 6 - Audio Signal Flow Block Diagram



S  
E  
R  
V  
I  
C  
E

Figure 5 - Power Distribution Block Diagram

**Quadrature Detector Adjustment**

1. Inject a strong on channel signal at the antenna jack modulated with 1 kHz tone at 1.5kHz deviation.
2. Monitor VQL/SQ HI J705-3 with an AC voltmeter and adjust L509 for a peak on the meter.

**RX AUDIO LEVEL Set**

1. Inject a strong on channel signal modulated by a 1 kHz tone at 3 kHz deviation at the RF input.
2. Monitor RX AUDIO J703-6 on the Audio Board with an AC voltmeter and adjust R513 for a reading of  $1.0 \pm 0.1$  Vrms.

**Squelch Adjust**

1. Select any channel and apply a signal modulated with a 1 kHz tone at 3 kHz deviation to the antenna input jack J101.
2. Using an insulated tool, turn R602 to the maximum counterclockwise position.
3. While monitoring SPKR HI J725-3, adjust the signal generator for 8 dB SINAD.
4. Adjust R602 fully clockwise then adjust counterclockwise until squelch just opens.

**TRANSMIT VERIFICATION****Transmit Frequency**

Key the transmitter and measure the transmit frequency. The measured frequency should be the programmed frequency  $\pm 100$  Hz.

**Transmitter Power/Current**

Select a channel at the upper band limit and the lower band limit and key the transmitter while measuring power and current. Power should be 40 watts  $\pm 0.5$  dB. Current should be less than 9.5 amperes.

**Modulation Limiting**

1. Apply a 1 kHz 300 mVrms signal to the microphone input at J725-4 to the channel to be tested.

2. Key the transmitter and verify that the deviation is  $< 4.5$  kHz. Test all channels.

**NOTE**

For this test and the following test, the modulation analyzer should have no highpass filter and a 15 kHz lowpass filter selected.

**Transmitter Distortion**

1. Inject an audio tone of 1 kHz at MIC HI J725-4. The tone should have enough amplitude to produce  $2 \pm 0.2$  kHz deviation when the transmitter is keyed.
2. Deemphasize the transmitted signal, and measure distortion. Distortion should be less than 3%.
3. Transmit on a channel with the lowest Channel Guard tone frequency and measure distortion. Distortion should be less than 3%.

**Transmitter Hum and Noise**

Measure residual hum and noise with a modulation analyzer referenced to a 1 kHz tone at 3 kHz deviation. Setting should include 750uS deemphasis, 300 Hz highpass filter, and 3000 Hz lowpass filtering. Measure at the upper end of the band. H/N should be greater than 48 dB.

**RECEIVER VERIFICATION****SINAD**

Apply the proper RF signal modulated with 1 kHz tone at 3 kHz deviation to the antenna jack J101. Set the signal level to -116 dBm. Check for greater than 12dB SINAD at the upper and lower band limit.

**Audio Distortion**

Apply a strong ( $> -50$  dBm) on-frequency signal modulated with 1 kHz at 3 kHz deviation. Monitor SPKR HI J725-3 and adjust the volume for 3 watts output (3.46 Vrms into 4 ohms). Distortion should be less than 5%.

**Receiver Hum and Noise**

Apply and monitor the same signal given in the Audio Distortion measurement above. Use the 3 watt output as a

reference. Turn off the 1 kHz tone modulation and measure the residual hum and noise. H/N should be greater than 48 dB.

**NOTE**

Signal generator must be of sufficient quality to not limit the radio H/N performance.

**Channel Guard Decoding**

Select a channel with the highest operating Channel Guard tone. Apply an on carrier signal of -116 dBm modulated with the above tone at 500 Hz deviation. Verify that the squelch opens.

the System Board by way of the Logic Board and the Control Board. RX AUDIO is attenuated and switched with the Public Address audio on the System Board. ATTN RX AUDIO leaves the System Board to feed the digital volume control and the 3 watt Audio PA on the Control Board. SPKR HI audio from the 3 watt PA leaves the Control Board to feed the System Board where the speaker is connected.

### LOGIC SIGNAL FLOW

Refer to Figure 7 - Logic Signal Flow Block Diagram for an understanding of the distribution of logic signals throughout the radio. Microprocessor U701 on the Logic Board provides synthesizer data to the RF Board, control signals to the FET switches on the Audio Board, and display serial data to microprocessor U725 in the Front Cap Assembly. U701 also accepts squelch and tone data from the Audio Board, PTT signals from the microphone, and keypad serial data from U725 in the Front Cap. All logic lines should have 4-5 volts for a logic high and less than 0.5 volts for a logic low.

### TRANSMITTER ALIGNMENT

Figure 3 below provides a test set up configuration. Alignment controls and test points are identified in Figure 4.

#### VCO Set

1. Select a frequency within 200 kHz of the upper band limit and key the transmitter. (G1 - within 200 kHz of 153 MHz.) (G2 - within 200 kHz of 174 MHz).
2. Adjust R218 on the RF Board for 6.5 VDC  $\pm$ 0.2 volts as measured at J201 on the RF Board.

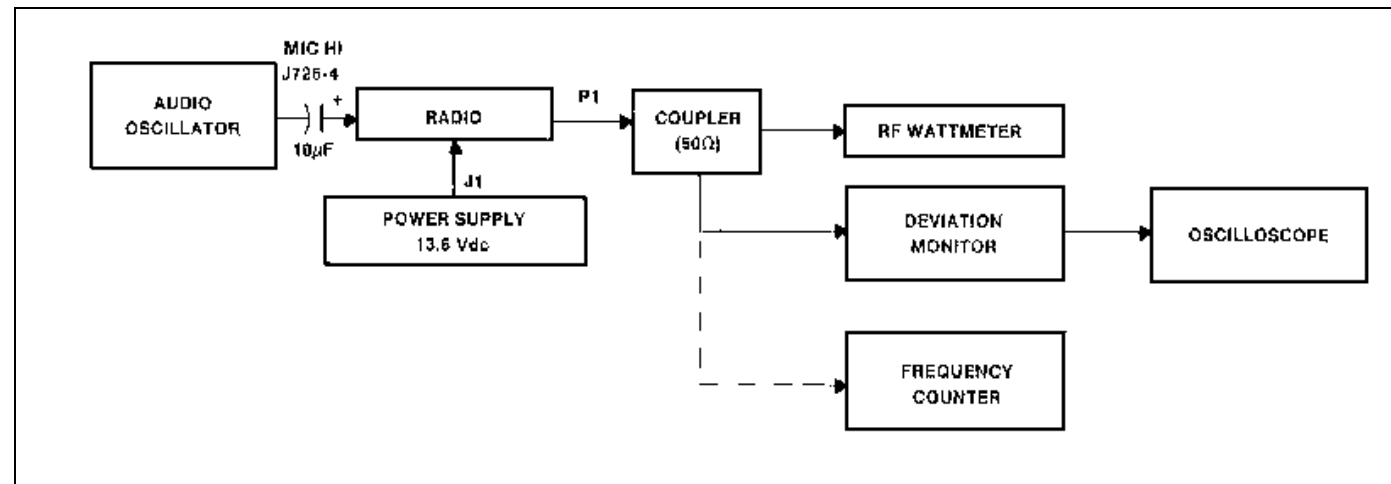

Figure 3 - Test Configuration

### Frequency Set

1. Select any channel and key the transmitter.
2. While holding the transmitter keyed, check the frequency output of the transmitter and adjust reference oscillator U204 to within  $\pm$ 50 Hz of the channel frequency. The operating temperature of the radio should be 25 degrees Celsius  $\pm$ 5 degrees.

### Transmitter Power Set

1. Adjust R111 in the power control circuit fully clockwise.
2. Check all transmit channels and select the channel with the lowest output power level. Note this power level.
3. Turn R111 down until the output power is at least 1 watt lower than the noted maximum power. Do not exceed 40 watts. (The minimum power specification is 35 watts.)

**NOTE**  
R111 should always be adjusted to a point where the power control circuit is reducing the output power. Failure to do this will defeat the power leveling function of the control circuit and may cause abnormally high output power levels at other frequencies.

### Deviation Adjustment

1. Select the channel representing the lowest operating frequency and the lowest Channel Guard frequency.
2. Apply a 1 kHz 300mVrms signal to the microphone input at J725-4. 8 volts is present on MIC HI and a blocking capacitor may be needed (10 $\mu$ F).
3. Key the transmitter and adjust R226 on the RF Board for 4.5 kHz  $\pm$ 0.1 kHz deviation. The modulation analyzer should have no highpass filter, and a 15 kHz lowpass filter selected.

**NOTE**  
Make sure that deviation is set on a channel with Channel Guard present to prevent over deviation.

### RECEIVER ALIGNMENT

#### Frequency Set

1. Verify that the transmitter is on frequency as described in the transmitter alignment above.
2. Inject a strong on channel signal at the antenna J101.
3. Monitor J501 with a frequency counter and adjust L508 for a reading of 455 kHz  $\pm$ 100 Hz.

#### RF and IF Tuning

1. Select a frequency within 200 kHz of the upper band edge of the radio. (G1 - within 200 kHz of 153 MHz.) (G2 - within 200 kHz of 174 MHz.)
2. Monitor J501 with an AC voltmeter and inject an on channel signal modulated by 1 kHz tone at 5 kHz deviation at the antenna jack.
3. Adjust L504, L506, and L507 for a peak on the voltmeter. Adjust the level of the signal generator to keep the signal at J501 out of limiting.
4. Repeak the coils.
5. Adjust C408 for peak.

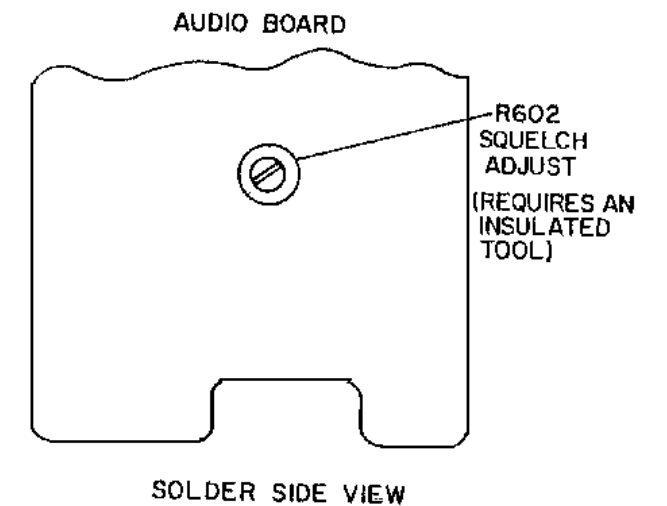
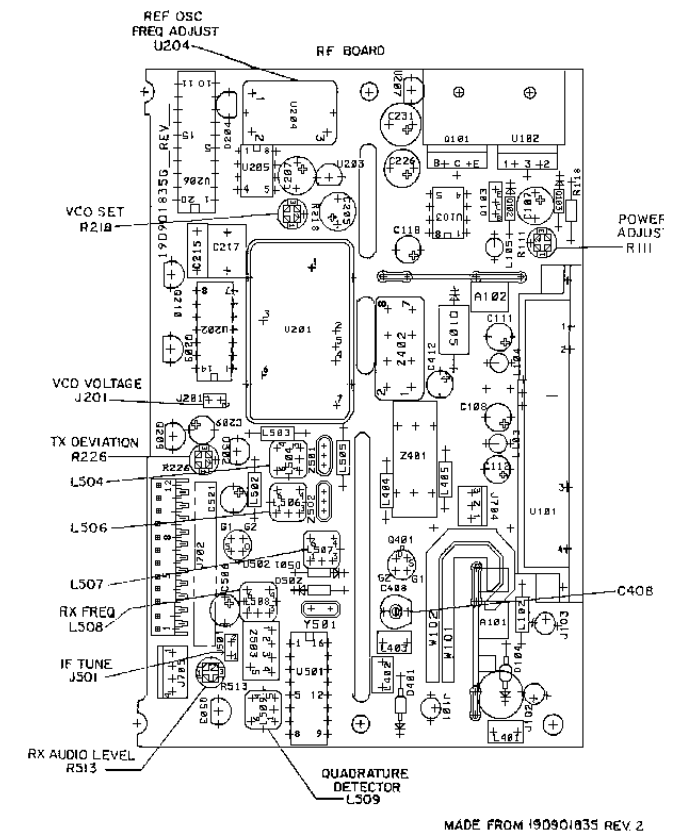

Figure 4 - Alignment Controls And Test Points

S  
E  
R  
V  
I  
C  
E

## SYMPTOMS AND CHECKS

SYMPTOMS	CHECKS
<ul style="list-style-type: none"> <li>• Low TX Power</li> </ul>	<p>Check the TX frequency:</p> <p>If the TX frequency is out of the band, check the synthesizer on the RF Board. Check the synthesizer load commands from the Logic Board. If the commands are not present, a problem on the Logic Board is likely.</p> <p>If the TX frequency is correct, bypass the 40 watt PA Board by placing a jumper between J 102 and J 103 on the RF Board. The PA Module on the RF Board should provide 10 watts output. If not, refer to the RF Board LBI and troubleshoot the transmitter.</p>
<ul style="list-style-type: none"> <li>• No TX Modulation</li> </ul>	<p>Check the TX MOD input to the RF Board. If present, the problem is most likely on the RF Board. If not present, determine what is missing: Channel Guard tones, voice, or both.</p> <p><u>Missing Tone</u> - Look at the Signalling Tone input to the Audio Board.</p> <p>If the Tones are not present the problem is most likely on the Logic Board.</p> <p>If the tones are present, look for the proper unmute commands to the Audio Board from the Logic Board. If the commands are not present, the problem is most likely on the Logic Board.</p> <p>If the commands are present the problem is most likely on the Audio Board.</p> <p><u>Voice Signal Missing</u> - Again, check the mute command from the Logic Board. Check the MIC HI input to the Audio Board. If all signals are correct, the problem is most likely on the Audio Board.</p>
<ul style="list-style-type: none"> <li>• Distorted TX Audio</li> </ul>	<p>Check for good grounding of all boards to the casting.</p> <p>Check for the presence of board shields on the bottom of the radio.</p> <p>Check the TX MOD input to the RF Board. If distorted, a problem on the Audio Board is likely.</p> <p>Check the mute commands. If incorrect, a difficulty on the Logic Board is indicated.</p> <p>If only the tones are distorted, a Logic Board problem is likely (faulty tone generation).</p>
<ul style="list-style-type: none"> <li>• TX Off Frequency</li> </ul>	<p>This is most likely a problem on the RF Board. Refer to the frequency set instructions in the transmitter alignment section in this LBI. Check the synthesizer load command. If the load command is improper a Logic Board problem is likely.</p>

## POWER DISTRIBUTION

Refer to Figure 5 - Power Distribution Block Diagram for an understanding of the distribution of A+, SW A+, and the regulated voltages throughout the radio.

**A+**

A+ (13.8 volts nominal) enters the radio on the power cable and is connected to the System Board. A+ feeds the MOSFET switch Q903 which provides SW A+ power for the radio. A+ leaves the System Board on J903 and feeds the PA Board through feedthru capacitor assembly Z903.

A+ powers the RF transistor on the PA Board. D151 on the PA Board provides reverse polarity protection for the radio. A+ leaves the board on J151 and feeds the RF Board.

A+ powers the 10 watt PA Module on the RF Board. D 105 provides over-voltage spike protection for the radio. A+ also feeds the power control transistor Q101 which supplies the power control voltage to the PA Module.

**SWA+**

Switched A+ (13.6 volts nominal) originates from the MOSFET switch on the System Board. The Ignition Sense lead and the POWER pushbutton control the MOSFET switch. Fuse F901 protects the MOSFET and the radio from high current failures. SW A+ leaves the board on J902 and on J903. J902 provides SW A+ to power all circuitry in the Front Cap Assembly (the 5 volt regulator, the 3 watt audio PA, and the LCD backlighting). J903 provides SW A+ to the PA Board. The PA Board does not use SW A+ but passes SW A+ to the RF Board.

SW A+ enters the RF Board on J704 and J705. SW A+ supplies power to three 8 volt regulators and the transmitter power control. SW A+ leaves the RF Board on J902 to feed the SW A+ filter circuit Q703 on the Logic Board. Q703 reduces alternator whine interference. The Logic Board does not use SW A+ or SW A+ FILTERED. The Logic Board supplies SW A+ FILTERED to the Audio Board through P703.

**REGULATED VOLTAGES**

SW A+ is the source of power for all voltage regulators. Several 5 volt regulators receive power from an 8 volt regulator to allow less power dissipation in the 5 volt regulators.

**RF Board**

The receiver has an 8 volt regulator U502. The synthesizer has a separate 8.3 volt regulator (U207) and a 5 volt regulator

U203. The transmitter uses another 8 volt regulator (U102). The output of U102 is switched to the exciter and the power control circuit. (U102 also powers the Logic Board. U102 (TX 8 volt supply) and Q101 (power control output transistor) are mounted for heat sinking.

**Logic Board**

A single 5 volt regulator U705 is used to power the Logic Board. The input voltage is derived from the 8 volt TX regulator U102 on the RF Board. The power-on reset circuitry for the Logic Board microprocessor is part of regulator U705. This reset signal prevents scrambled operation due to low voltage transients during automobile starting.

**Audio Board**

An 8 volt regulator U606 provides power to all of the Audio Board circuitry except U603. SW A+ FILTERED from the Logic Board provides the input voltage to the regulator.

**Front Cap Assembly (Control Board)**

A 5 volt regulator U727 powers the microprocessor logic, the digital volume, and the Control Panel backlighting.

## AUDIO SIGNAL FLOW

Refer to Figure 6 - Audio Signal Flow Block Diagram for an understanding of the distribution of RX and TX audio signals throughout the radio. Audio levels at important points are also shown.

**TRANSMITTER AUDIO**

Microphone audio (MIC HI) is routed from the mic connector on the Control Board through the Logic Board to feed the Audio Board. After processing and summing the Channel Guard tones, the audio (TX MOD) is fed through the Logic Board to the RF Board. TX MOD is adjusted by Deviation Adjust R226 before feeding the modulation input to the synthesizer VCO.

**RECEIVER AUDIO**

Discriminator audio is buffered by Q503 on the RF Board and adjusted by R513. This audio (VOL/SQ HI) is routed to the Audio Board by way of the Logic Board. On the Audio Board, VOL/SQ HI feeds 3 paths. Two paths (not shown on the block diagram) are the squelch path and the tone path to process tones for decoding in the Logic Board microprocessor. The third path is the RX Audio path which is filtered and routed to

5. System Board

Contains:

- A+ switching circuitry
- Option connections
- Public address mic amplifier

6. Front Cap Assembly

Contains:

- Control Panel
- LCD Assembly
- Control Board - includes a microprocessor, digital volume control, and 3 watt audio PA.
- Speaker

**Power-on Checks**

The MVS radio provides several self diagnostic checks when power is applied and informs the user of a possible problem within the radio. These tests provide the following error codes on the LCD display when a problem is detected:

- E0: Synthesizer is unlocked in receive. (Also an alert tone will sound.) The Logic Board is continuously reloading the synthesizer with data trying to achieve lock. Slowly stepping through different channel frequencies may reveal some channels that will lock. The synthesizer load commands or the VCO adjustment may not be correct.
- E1: Personality EEPROM not programmed with customer information.
- E2: EPROM program memory checksum error. If the Logic Board microprocessor uses external memory, the EPROM may be corrupted or malfunctioning.
- E3: Either no Control Panel connected or a new Control Panel has been added to the radio with a new channel capacity. The radio's personality must be PC programmed to specify 2, 16, or 128 channels to match the channel capacity of the Control Panel.

A properly operating radio will display all LCD indicators for 1/2 second when the power is turned on. The display will then show the channel selected when the radio was last operated.

**Control Panel Test**

The MVS radio provides a means for testing the switches on the Control Panel. If any button is held in and the power is

turned on simultaneously, the LCD will display "S" ("switch") in the channel indicator and the number of the switch in the mode indicator. Figure 2 shows how each Control Panel switch is numbered in the test.

For Example: If the MON button is held in, and the POWER button is pressed, the LCD will display S4. The radio will not resume normal operation until the power is turned off and back on without holding down another button.

**Front Cap Assembly Test**

The Front Cap Assembly test primarily checks the operation of the LCD assembly and microprocessor U725 on the Control Board. The Front Cap may be tested separated or connected to the radio.

1. Remove the Front Cap Assembly.
2. Plug the ribbon cable from the System Board back into J901 to supply SW A+ (13 Vdc) to the Front Cap. Connect the ribbon cable without looping the cable through the front of the radio assembly for easier access to the Control Board. The Front Cap may also be tested separate from the radio assembly by supplying 13 volts to J901 pins 5 or 6.
3. With power off, shortpin 19 of the Control Board microprocessor U725 to ground (pin 20). Apply power to the Front Cap, and if desired, remove the pin 19 short.
4. The Front Cap is now in the test mode with all LCD display segments on. Each segment should be turning off and then back on at approximately one second intervals.
5. Press each of the Control Panel switches. The LCD will display "S" (switch) in the channel indicator and the number of the switch in the mode indicator. Figure 2 shows how each switch is numbered. When a switch is released, the LCD will resume turning off each segment.
6. To leave the test mode, remove power and then reapply power without the pin 19 short.

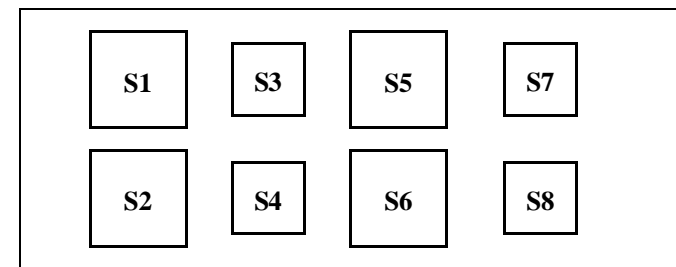
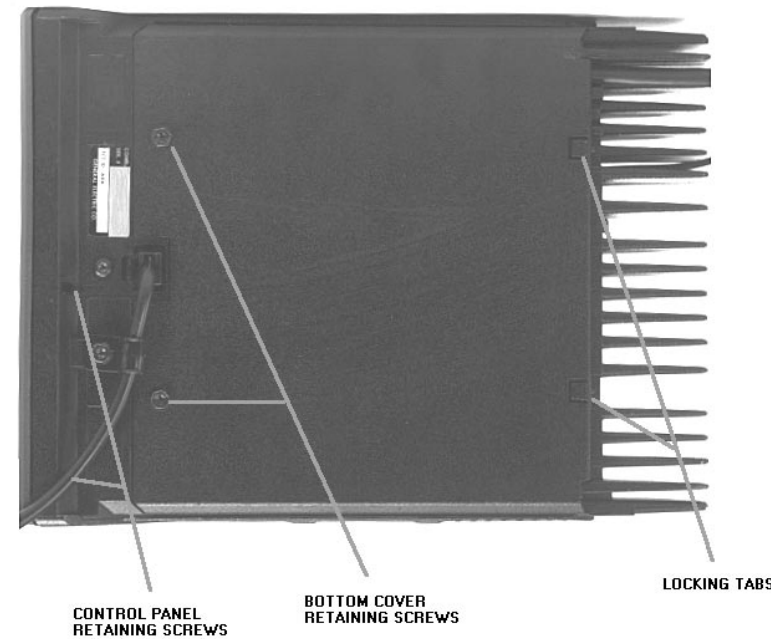

Figure 2 - Switch Numbers For The Control Panel Test

SYMPTOMS AND CHECKS

SYMPTOMS	CHECKS
<ul style="list-style-type: none"> <li>• Radio does not power-up. (No display indicators on)</li> </ul>	Check for SW A+ at the Control Board in the Front Cap Assembly. SW A+ originates from the System Board through fuse F901.
<ul style="list-style-type: none"> <li>• Radio powers-up with S 1 through S 8 in the display</li> </ul>	A Control Panel switch is being pushed while turning on the radio power.
<ul style="list-style-type: none"> <li>• Radio powers-up with all LCD indicators on, but they remain on</li> </ul>	The Control Board may not be receiving serial data from the Logic Board. Check for correct DC voltages on the Logic Board.
<ul style="list-style-type: none"> <li>• Low, Distorted or No RX Audio</li> </ul>	<p>Check the receiver VOL/SQ HI output. If audio is improper the problem is most likely on the RF Board. If synthesizer load commands are not correct, the problem maybe on the Logic Board.</p> <p>If the audio is correct at VOL/SQ HI, check the Audio Board RX AUDIO output. If improper, check the Audio Board for proper unmute commands from the Logic Board. Improper commands indicate a Logic Board problem. Proper commands indicate an Audio Board problem.</p> <p>If RX AUDIO is correct, check the ATTENUATED RX AUDIO feeding the Control Board. If improper, check the Public Address Mute command on the System Board.</p> <p>If ATTENUATED RX AUDIO is correct, the problem may be either the digital volume control or the 3W audio PA on the Control Board in the Front Cap Assembly.</p>
<ul style="list-style-type: none"> <li>• No RX Alert Tones (Radio OK Otherwise)</li> </ul>	<p>Check the Signalling Tone output from the Logic Board. Operate the volume control. If tones are not present, a problem on the Logic Board is indicated.</p> <p>If the tones are present, the problem is most likely on the Audio Board, unless the mute commands from the Logic Board are improper.</p>
<ul style="list-style-type: none"> <li>• Poor RX Sensitivity</li> </ul>	The problem is most likely on the RF Board. Check the receiver alignment. Refer to the RF Board LBI for additional service notes.
<ul style="list-style-type: none"> <li>• No TX Power</li> </ul>	Check the DPTT command to the RF Board. If present, then the problem is most likely on the RF Board. If the DPTT is not present, the problem is most likely on the Logic Board.
<ul style="list-style-type: none"> <li>• No TX Power and alert tone immediately heard when PTT keyed</li> </ul>	Synthesizer on RF Board is unlocked or became momentarily unlocked. Possible power source problem or resistive A+ connections. (The voltage momentarily dropped below 10 volts when the transmitter tried to pull 9 amps which caused the synthesizer to unlock, turning off the transmitter, and sounding the alert tone.)





### **Control Panel Removal**

1. Remove the two M3.5-0.6 x 8 TORX screws (#15 drive) from the rear of the front cap assembly if not already removed.
2. Gently pull the control panel away from the front cap and disconnect the ribbon cable on the rear of the panel.

### **LCD Removal**

To remove the LCD assembly, the Control Panel must first be removed to expose the mounting screws. To remove the assembly, simply remove the three mounting screws and pull the assembly out of the casting. When replacing the screws, use only a moderate torque of 4 inch-pounds. Over-tightening may prevent the power switch from operating.

## **COMPONENT REPLACEMENT**

The procedure for removing chip components is given below. Replacement procedures for other unique components are found in the appropriate board LBI where the component is used (the 40 watt PA transistor replacement in the PA Board LBI and the 10 watt PA module replacement in the RF Board LBI).

### **CHIP COMPONENT REPLACEMENT**

Replacement of chip capacitors should always be done with a temperature controlled soldering iron, using a controlled temperature of 70F (371C). However, do NOT touch black metal film of the resistors or the ceramic body of capacitors with the soldering iron.

#### **NOTE**

The metalized end terminations of the parts may be touched with the soldering iron without causing damage.

To Remove Chip Components:

1. Using two soldering irons heat each end of the chip at the same time until solder flows, and then remove and discard the chip.
2. Remove excess solder with a vacuum solder extractor.
3. Carefully remove the epoxy adhesive and excess flux to prevent damage to the printed board.

To Replace Chip Components:

1. Using as little solder as possible, "tin" one end of the component and one of the pads on the printed wiring board.
2. Place the "tinned" end of the component on the "tinned" pad on the board and simultaneously touch the component and the pad with a well "tinned" soldering iron while pressing the component down on the board.
3. Place the "tinned" soldering iron on the other end of the component and the pad simultaneously. Apply solder to the top of the end of the component until the solder starts to flow. Use as little solder as possible while getting a good joint.
4. After the component has cooled, remove all flux from the component and printed wiring board with alcohol.

#### **CAUTION**



The CMOS Integrated Circuit devices used in this equipment can be destroyed by static discharges. Before handling one of these devices, the serviceman should discharge himself by touching the case of a bench instrument that has a 3-prong power cord connected to an outlet with a known good earth ground. When soldering or desoldering a CMOS device, the soldering iron should also have a 3-prong power cord connected to an outlet with a known good earth ground. A battery-operated soldering iron may be used in place of the regular soldering iron.

## **TROUBLESHOOTING PROCEDURE**

This section should help isolate a problem to a particular board or circuit. Troubleshooting charts and block diagrams for power distribution and signal flow are given. Refer to the appropriate LBI on the suspect board for additional troubleshooting and circuit information.

The MVS radio is divided into 6 functionalized boards or assemblies. The outline below gives a quick list of the major functions for each board. Refer to the appropriate LBI on each for more details.

### 1. RF Board

Contains:

- Synthesizer - generates all transmit and receive frequencies.
- Receiver - provides detected audio to the Audio Board.
- Transmitter - includes exciter and 10 watt PA Module.
- Power control circuitry for the transmitter.
- Pin diode TX/RX RF switch.
- Lowpass filter for the transmitter.

### 2. PA Board

- Amplifies the RF Board 10 watt output to 40 watts which is fed back to the RF Board.

### 3. Audio Board

Contains:

- RX squelch - provides the CAS signal to the Logic Board.
- RX Audio - provides filtered and gated audio to the System Board.
- Tone processing - provides receiver tone data to the Logic Board.
- TX Audio - processes the mic and tone audio to feed the RF Board synthesizer.

### 4. Logic Board

- Routes signals between the RF, Audio, and Control Boards.
- Contains the EEPROM for the radio personality.
- Contains the main radio microprocessor.
- Accepts PTT from the microphone.
- Provides DPTT to turn on the transmitter.
- Provides synthesizer channel data to the RF Board.
- Decodes tone data from the Audio Board.
- Generates the Channel Guard tones and data.
- Controls all audio switches on the Audio Board.
- Accepts the CAS squelch output from the Audio Board.

## CONNECTIONS

Ground connections to the voltage source should be periodically checked for tightness. Loose or poor connections to the power source will cause excessive voltage drops and faulty operation. When ground connections are not made directly to the battery, the connection from the battery to vehicle chassis must be checked for low impedance. A high impedance may cause excessive voltage drops and alternator noise problems.

## ELECTRICAL SYSTEM

Check the voltage regulator and alternator or generator periodically to keep the electrical system within safe and economical operation limits. Overvoltage is indicated when the battery loses water rapidly. Usage of 1 or 2 ounces of water per cell per week is acceptable for batteries in continuous operation. A weak battery will often cause excessive noise or faulty operation.

## MECHANICAL INSPECTION

Since mobile units are subject to constant shock and vibration, check for loose plugs, nuts, screws and other parts to make sure that nothing is working loose.

## ANTENNA

The antenna, antenna base and all contacts should be kept clean and free from corrosion. If the antenna or its base should become coated or poorly grounded, loss of radiation and a weak signal will result.

## ALIGNMENT

The transmitter and receiver meter readings should be checked periodically, and the alignment "touched up" when necessary. Refer to the Alignment Procedure in this service manual.

## FREQUENCY CHECK

Check transmitter frequency and deviation. Normally, these checks are made when the unit is first put into operation, after the first six months, and once a year thereafter.

## DISASSEMBLY PROCEDURE

### TO REMOVE THE TOP COVER

1. Insert a small standard screwdriver under one side of the top cover and gently pry the side of the cover away from the frame releasing the locking tab (refer to Figure 1).
2. Using the screwdriver, press in on the tabs on the rear of the radio and release the two locking tabs.
3. Insert the screwdriver under the other side of the radio top cover, releasing the remaining locking tab, and remove the cover from the radio.

### TO REMOVE THE BOTTOM COVER

Remove the two screws securing the bottom cover to the radio. One of the screws is used to hold the microphone strain relief (refer to Figure 1). The bottom cover can then be removed from the radio.

### TO REMOVE THE RF BOARD

1. Remove the top and bottom covers from the radio (refer to the procedure above).
2. Pry off the friction fit covers covering the RF Board.
3. Gently pry interconnect plug P702 from the Logic and RF Boards using a small standard screwdriver.
4. Remove the two M3.5-0.6 x 8 TORX screws (#15 drive) securing Q101 and U102 to the frame (on top side of board).
5. Remove the two M3.5-0.6 x 20 TORX screws (#15 drive) securing PA module U101 to the frame.
6. Remove the five M3.5-0.6 x 8 TORX screws (#15 drive) from the bottom side of the board.
7. Disconnect wires attached to J704, J705 and cables going to the PA Board.
8. Remove the six spring clips protruding through the RF Board from the bottom side.
9. Gently push the RF board out of the radio casting.

### TO REMOVE THE AUDIO BOARD

1. Pull out the black clip protruding through the Audio Board which holds the Logic Board 5 volt regulator against the casting.
2. Remove the four M3.5-0.6 x 8 TORX screws (#15 drive) securing the Audio Board to the radio. Pry out the board using a screwdriver in the hole that was occupied by the clip.

### TO REMOVE THE LOGIC BOARD

1. Remove the top cover, bottom cover, Front Cap assembly and the Audio Board from the radio. Refer to the disassembly for each in this section.
2. Remove interconnect plug P702 from the RF and Logic Boards on the bottom of the radio.
3. Remove the four M3.5-0.6 x 8 TORX screws (#15 drive) securing the Logic Board to the radio frame.
4. Carefully work the Logic Board out of the radio being careful not to damage the plug going to the Front Cap Assembly.

### TO REMOVE THE PA BOARD

1. Remove the top cover of the radio. Refer to the procedure above.
2. Disconnect the cables going back to the RF Board.
3. Disconnect the cable at J151 on the PA Board.
4. Remove the two M2.5-0.45 x 8 TORX screws (#8 drive) securing the PA transistor to the frame.

#### NOTE

When re-installing the PA Board in the radio, the PA transistor screws should be installed and torqued to 4.5 inch-pounds before tightening down the screws securing the board to the casting to 15 inch-pounds.

5. Remove the four M3.5-0.6 x 8 TORX screws (#15 drive) securing the board to the frame. Carefully work the board out of the radio, unplugging it from the feed thru assembly Z903.

### TO REMOVE THE SYSTEM BOARD

1. Remove the bottom cover of the radio. Refer to the procedure above.
2. Disconnect the speaker leads from J904.
3. Disconnect the ribbon cable from J902.
4. Disconnect the option cable if used.
5. Remove the three M3.5-0.6 x 8 TORX screws (#15 drive) securing the board to the frame.
6. Carefully work the board out of the radio, unplugging it from the feed thru assembly Z903.

### TO REMOVE THE FRONT CAP ASSEMBLY

1. Remove the top and bottom covers of the radio.
2. Remove the two M3.5-0.6 x 8 TORX screws (#15 drive) from both sides of the front cap and the TORX screw on the bottom of the front cap. Also on the bottom, remove the two screws securing the control panel to the front cap assembly.
3. Gently pull the front cap assembly away from the radio exposing the ribbon cable on the rear of the assembly.
4. Disconnect the ribbon cable from the rear of the assembly and disconnect the speaker leads from the System Board. The Front Cap Assembly can then be removed from the radio.

### FRONT CAP DISASSEMBLY

The Front Cap Assembly consists of: the Control Board, the Control Panel, the LCD assembly, and the internal speaker. The following procedures describe how to remove the Control Board, the Control Panel, and the LCD assembly after the front cap has been removed from the radio.

#### Control Board Disassembly

1. Disconnect the ribbon cables at J726 and J727.
2. Remove the two clips securing 5 volt regulator U727 and 3 watt PA U801 to the front cap casting.
3. Remove the four M3.5-0.6 x 8 TORX screws (#15 drive) securing the board to the front cap casting. Lift the board out of the front cap.